

Ersatzteilliste / list of spare parts

Motor und Getriebe 5,5kW/7,5kW Baureihe GFL / motor and gear 5,5kW/7,5kW type series GFL

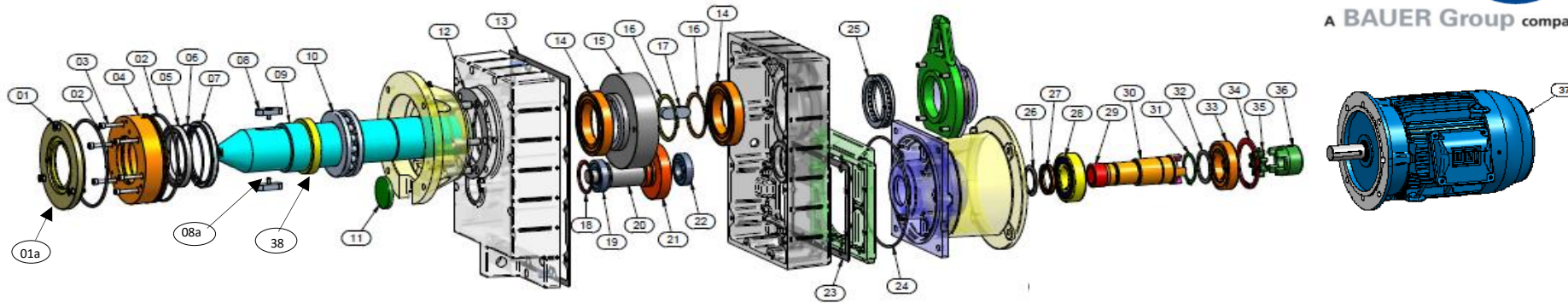

A BAUER Group company



Pos	Bezeichnung / description	Menge Quantity	Pos	Bezeichnung / description	Menge Quantity	Pos	Bezeichnung / description	Menge Quantity
01a	Deckscheibe/covering disc	1	13	Gehäusedichtung/body seal	1	27	Wellendichtring/shaft sealing ring	1
01	Senkschraube/counter sunk screw M8x35	3	14	Rillenkugellager/groove ball bearing	2	28	Rillenkugellager/groove ball bearing	1
02	O-Ring 190x5	2	15	Zahnrad Z6/gear wheel Z6	1	29	Einsteckritzel/insert gear pinion	1
03	Zylinderschraube/cylinder screw M8x55	6	16	Sicherungsring/retaining ring	2	30	Normanbauwelle/standard mounting shaft	1
04	Lagerring 2n - Dichtungsträger/bearing ring 2n-seal bracket	1	17	Passfeder/fitting key	1	31	Sicherungsring/retaining ring	1
05	WDR-Cassette 110x140x13,5x15,5 75 NBR 106200 TYP 3	1	18	Sicherungsring/retaining ring	1	32	Passscheibe/ shim ring	1
06	Federring/spring circlip	1	19	Kegelrollenlager/taper roller bearing	1	33	Rillenkugellager/groove ball bearing	1
07	Simmering/retaining ring 125x150x13	1	20	Ritzelwelle/pinion shaft	1	34	Sicherungsring/retaining ring	1
08	Passfeder/ fitting key	2	21	Zahnrad Z2/gear wheel Z2	1	35	Zahnkranz Rotex/geared ring rotex	1
08a	Schraube f.Passfeder/screw f.fitting key	2	22	Kegelrollenlager/taper roller bearing	1	36	Nabe Rotex/hub rotex	1
09	Hauptwelle/primary shaft	1	23	Gehäusedichtung/body seal	1	37	Motor/motor	1
10	Axiallager/axial bearing	1	24	O-Ring	1	37.1	Lüfterrad mit Befestigungsmat./fan wheel with mounting parts	1
11	Verschlussdeckel/cover plate	1	25	Axiallager/axial bearing	1	37.2	Lüfterhaube mit Befestigungsmat./fan cover with mounting parts	1
12	Gehäusedichtung/body seal	1	26	Dichtring/sealing ring	1	38	Lagerring/bearing ring	1
Ersatzteilsets -Artikelbezeichnung		sets of spare parts description			besteht aus /consists of (Menge siehe oben /quantity see above)			Artikel Nr. Part No.
Deckscheibe 3kW/4kW /5,5kW /7,5kW		covering disc for 3kW/4kW/ 5,5/7,5kW			Pos 01a			F110 99200
Hauptwelle 5,5kw		primary shaft 5,5kW			Pos 08, 08a,09, 11, 12, 13, 17, 23, 24,38			F110 99201
Hauptwelle 7,5kw		primary shaft 7,5kW			Pos 08, 08a, 09, 11, 12, 13, 17, 23, 24,38			F110 99202
Passfeder mit Schraube 3kW/4kW/5,5kW		fitting key with screw 3kW/4kW/5,5kW			Pos 08, 08a			F110 99219
Dichtungsträger 3kW/4kW/5,5kW/7,5kW		seal bracket 3kW/4kW/5,5kW/7,5kW			Pos 01, 02, 03, 04, 05, 06, 07			F110 99203
Lagerung Hauptwelle 5,5kW/7,5kW		bearing primary shaft 5,5kW/7,5kW			Pos 10, 11, 12, 13, 14, 16, 17, 23, 24, 25			F110 99204
Zahnrad Z6 5,5kW/7,5kW		gear wheel Z6 5,5kW/7,5kW			Pos 11, 12, 13, 15, 16, 17, 23, 24			F110 99205
Zahnrad Z2 und Ritzelwelle 5,5kW/7,5kW		gear wheel Z2 and pinion shaft 5,5kW/7,5kW			Pos 11, 12, 13, 18, 19, 20, 21, 22, 23, 24			F110 99206
Normanbauwelle mit Z1 5,5kW/7,5kW		standard mounting shaft with Z1 5,5kW/7,5kW			Pos 23, 24, 26, 27, 28, 29, 30, 31, 32, 33, 34, 35, 36			F110 99207
Motor 5,5kW		motor 5,5kW			Pos 37			F10699062
Motor 7,5kW		motor 7,5kW			Pos 37			F110 99209
Lüfterrad mit Befestigungsmaterial 5,5kW/7,5kW		fan wheel with mounting parts 5,5kW/7,5kW			Pos 37.1 (Motor Seriennr. erforderlich/motor serial nr. necessary)			F110 99225
Lüfterhaube mit Befestigungsmaterial 5,5kW/7,5kW		fan cover with mounting parts 5,5kW/7,5kW			Pos 37.2 (Motor Seriennr. erforderlich/motor serial nr. necessary)			F110 99222
Lagerring für 5,5kW/7,5kW		bearing ring f. 5,5kW/7,5kW			Pos 38			F11099227