



TF 1400

Thin Film Deposition Systems



The TF 1400 is designed to meet your mass production requirements for multi-layer dichroic coatings with a low cost of ownership. The system is designed for accommodating large volume electron beam guns of crucible capacity ranging from 25 cc to 235 cc coupled to a 12 kW power supply. A suitable combination of rotary, roots and diffusion pumps ensures optimal pumping times for maximizing productivity. Complete process automation guarantees process repeatability and the intelligent HMI software allows operators to quickly input data, set up procedures and change between process parameters ensuring ease-of-operation. This versatile high-volume coating system is ideal for large mass-manufacturing facilities that want to maximize their productivity with reliable and consistent coatings.

CHAMBER CONFIGURATIONS



Stand-alone system Configuration



Wall-mounted system Configuration

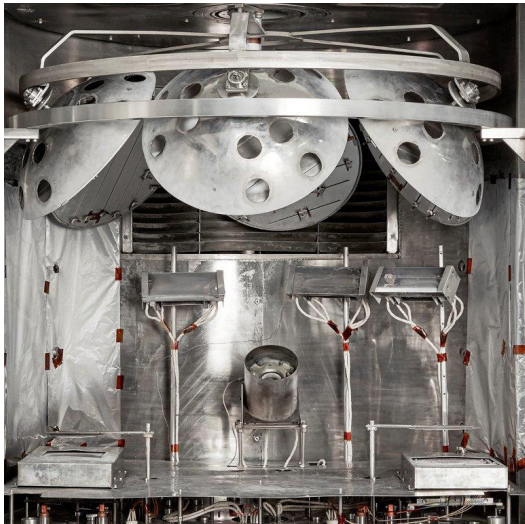

System inside view

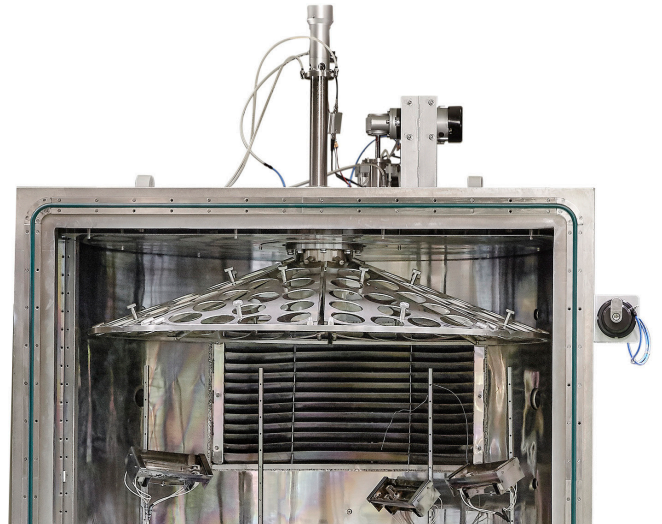

Domed work holder for ophthalmic applications



Planar planetary work holder

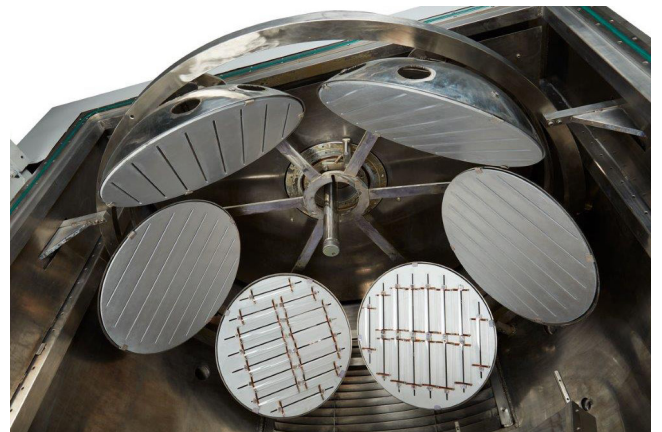

Knudsen planetary work holder with thickness monitor

SPECIFICATIONS

CHAMBER SIZE	1400 mm (Ø) x 1400 (H)
HV PUMPING OPTIONS	Diffusion pump as standard. Turbo and Cryo pumps options available
ROUGHING/BACKING OPTIONS	Rotary / Dry
BASE PRESSURE	Up to 10^{-6} mbar
SUBSTRATE SIZE	Customizable work holders to suit production needs over a working diameter of 1100 mm
SUBSTRATE HOLDER	Planar Planetary, Knudsen Planetary, Domed holder and other custom options

CONTROL OPTIONS

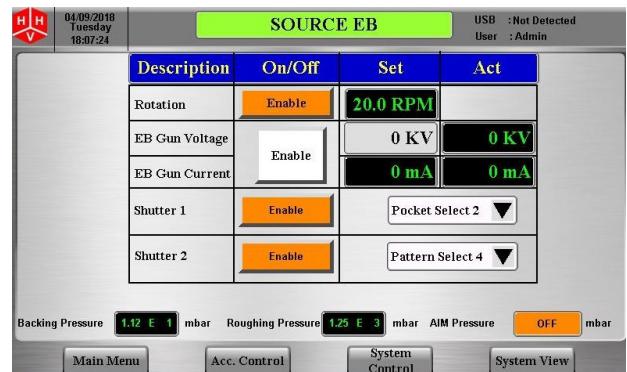
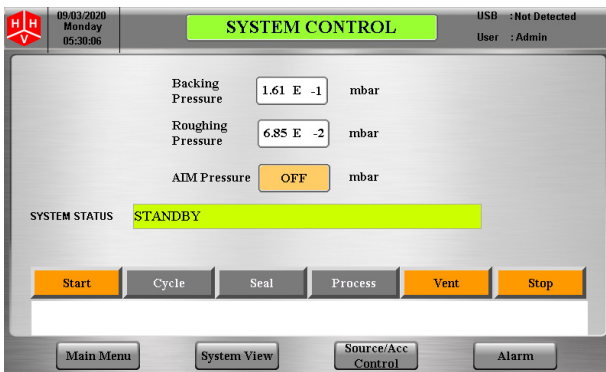

Touch screen HMI based operation

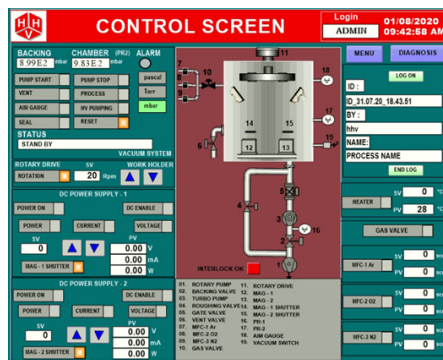

SCADA based system operation

RESULTS

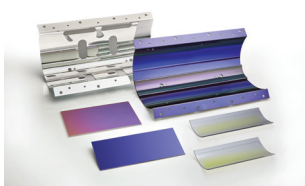

UV reflectors



Optical filters



Laser optics

FEATURES

- Proven for large volume industrial production
- Rugged components for high MTTR and MTBF
- Powerful and fast diffusion pumping system
- Supports large volume electron beam guns
- Clean room compatible
- Complete process automation

APPLICATIONS

- Anti- Reflection coatings
- UV reflector coatings
- Narrow band filters
- Laser optics
- Transparent conducting oxides
- IR coatings

LAYOUT

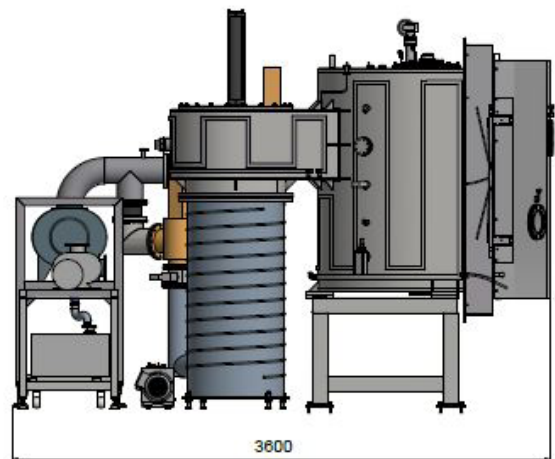
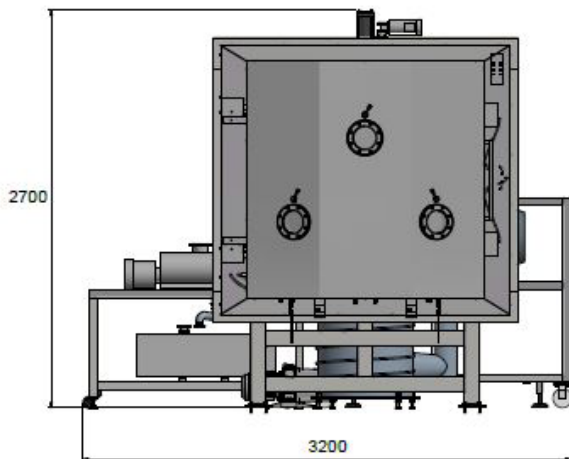

All dimensions in mm



Registered Office:

Hind High Vacuum Company Pvt. Ltd.
Site No. 17, Phase I Peenya Industrial Area
Bangalore 560058, India
Ph : +91-80-41931000
Email ID : infotfed@hhv.in | Website : www.hhv.in

Industrial Unit-2:

No. 31-34 & 37 KIADB Industrial Area,
Phase 1, Dabaspeta Nelamangala Taluk
Bangalore Rural – 562111 India
Ph : +91-80-66703700