

BT150 AND BT300 BENCH TOP SPUTTER COATERS



FULLY-FEATURED SYSTEMS FOR EM SAMPLE PREPARATION AND R&D

A new range of compact bench top systems with touch-screen control for SEM and TEM sample preparation, research and development



Process options

- Metals sputtering for SEM
- Carbon fibre evaporation for TEM
- Carbon rod evaporation for TEM
- Resistance evaporation
- Glow discharge
- Water-cooled SEM stage with bias function
- Rotary stages for SEM stubs
- Rotary stages for wafer substrates
- Integrated film thickness monitor

Control features

- Fully automatic touch-screen control
- User editable process control with storage for 30 recipes
- Automatic recognition of process accessories
- Rotary and turbo pump options

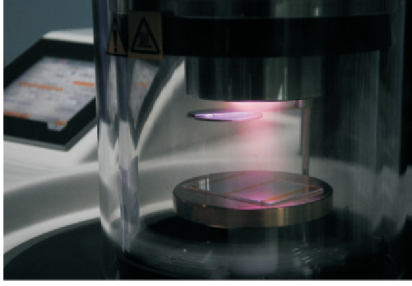

Above: Single sputter source for SEM

Right: BT150 with carbon fibre source in operation

Below: Carbon rod source for TEM

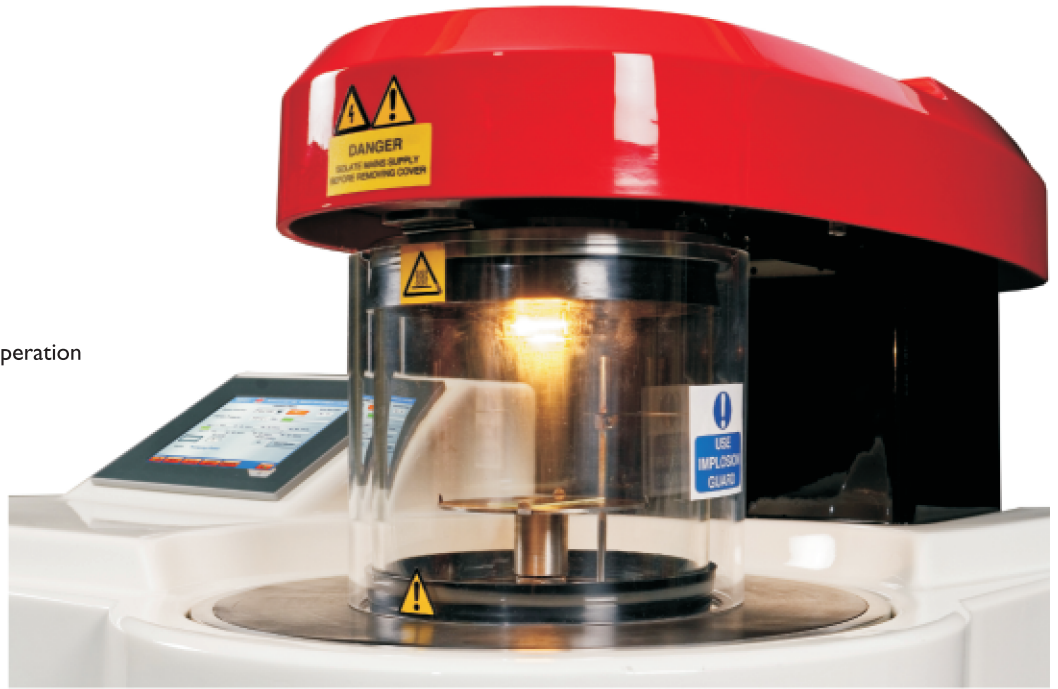
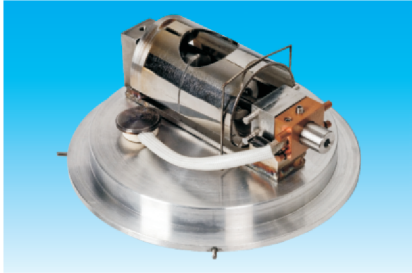

HHV BT150 and BT300

New bench-top deposition tools for EM sample prep and R&D

The new HHV BT150 and BT300 are compact and economical bench top coating systems designed to suit the needs of electron microscopists and researchers. BT150 provides comprehensive capability for the electron microscopist while the larger chamber of the BT300 extends the concept to provide additional process options for researchers.

The systems are designed to prepare specimens for scanning electron microscopy (SEM) by metals sputtering, and for transmission electron microscopy (TEM) by carbon evaporation from fibre or rods. The TEM carbon coating option also allows specimens to be prepared for X-ray microanalysis.

BT-series can also be configured for metals sputtering and metals evaporation for researchers

Touch screen control system for automatic sample coating:

Both systems are designed for ease of use and feature a full-colour, high resolution, touch screen control system. The control system can store up to 30 process recipes for easy recall and can output process data to a separate device for storage and analysis. The control system features automatic recognition of the deposition accessory that is fitted.

Wide range of sample stages:

BT-series features a wide range of sample stages. The static stage for SEM stubs features water cooling to provide protection against specimen heating, and includes a sputter etching and cleaning facility. Use of the etching facility can improve the image contrast of some specimens, and non-delicate specimens can be cleaned by removal of adsorbed water to improve film adhesion.

BT150 stage options include rotary and planetary designs for SEM stubs and rotary options for substrates up to 4" / 100mm. In addition to these the BT300 also features rotary and planetary stages for substrates up to 8" / 200mm diameter for research applications.

Integrated film thickness monitoring:

BT-series includes the option of a fully-integrated film thickness monitor system. The system is integrated into the touch-screen controller and provides control of the thickness of sputtered films.

Easy target change:

BT150 and BT300 use easy-to-change targets to allow specimens to be coated with different materials where required. Systems with rotary pump can sputter noble metals including Au, Au/Pd, Pt and Cu. Adding the optional turbo pump allows both systems to sputter oxidising metals such as Al for research applications.

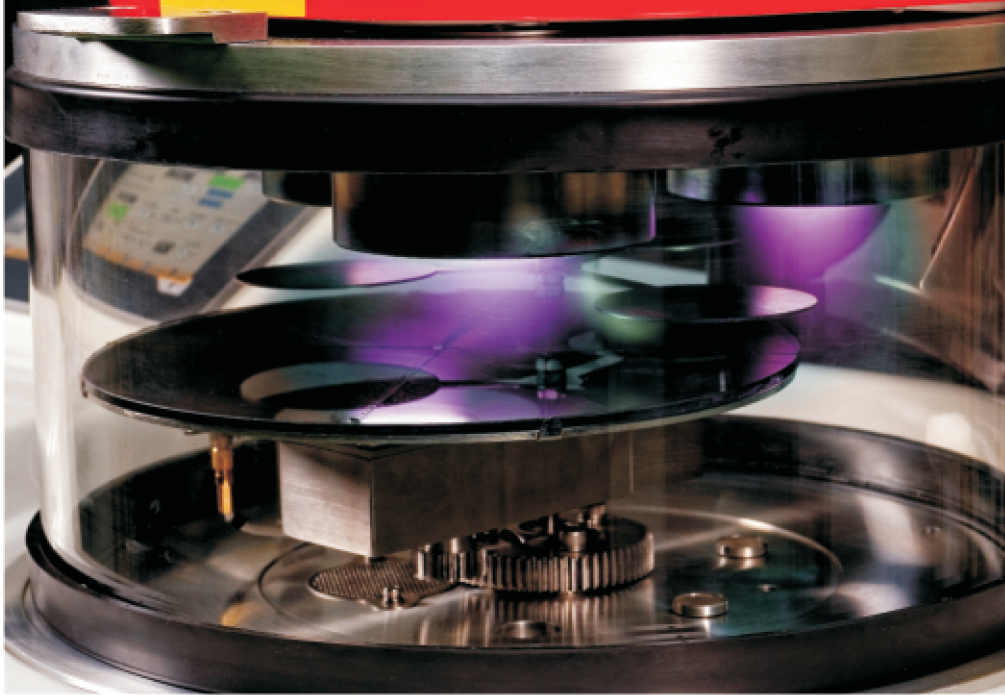

Above: Dual sputter sources for R&D
Left: BT300 with triple sputter sources and planetary stage



Below: Triple sputter sources for R&D

Vacuum pumping options:

The systems can be specified with a two-stage rotary pump for 'routine' operation with carbon and noble metals. The turbo pump option provides additional performance for those users requiring true high vacuum conditions, and the ability to sputter non-noble metals such as Al.

BT-series can be specified with a dry-running scroll pump where oil-free vacuum is required.

Comprehensive safety and certification:

BT150 and BT300 are provided with comprehensive safety systems and interlocks to provide protection for the user.

BT150 and BT300 are CE marked. UL-certification can be provided.

KEY FEATURES

Ease of operation

- Full colour, high resolution, touch screen control system
- Recipe storage and editing for up to 30 processes
- Process data output to mass storage device or PC
- Optional integrated film thickness monitoring system
- Automatic recognition of deposition accessories

Complete range of deposition techniques

- Noble metals sputtering techniques for SEM
- Carbon fibre and carbon rod techniques for TEM
- Glow discharge accessory for hydrophilic surface modification of carbon films for TEM
- Sputter deposition of metals such as aluminium for R&D (requires turbo pump option)
- Resistance source option for metals deposition for EM and R&D
- Automatic shutter options

A comprehensive range of sample stages

- Water cooled SEM stage with bias operation
- Rotary SEM stage
- Planetary SEM stage
- Rotary stage for R&D up to 4" / 100mm diameter (BT150)
- Rotary and planetary stages for R&D up to 8" / 200mm diameter (BT300)

BT150 AND BT300 BENCH TOP SYSTEMS

TECHNICAL INFORMATION

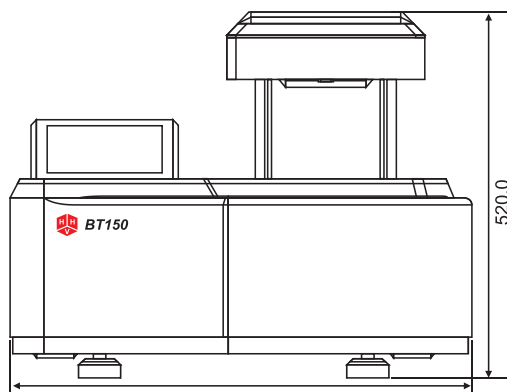

BT150 nominal dimensions (mm)

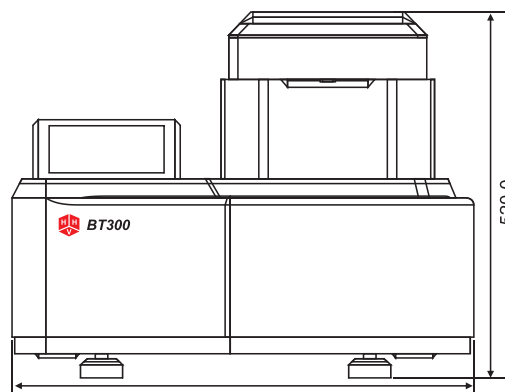

BT300 nominal dimensions (mm)

TECHNICAL DATA

| | |
|------------------------------------|--|
| BT150 | |
| Chamber | : Glass cylinder 165mm diameter x 150mm tall with implosion guard. Option for 200mm tall chamber |
| Rotary pump | : 12m ³ two-stage rotary pump. Option for dry scroll pump |
| Turbo pump option | : 62l/s compound turbomolecular pump with on-board controller |
| Ultimate vacuum (rotary pump only) | : 5x10 ⁻² mbar in <3 minutes |
| Ultimate vacuum (with turbo pump) | : 5x10 ⁻⁵ mbar in <8 minutes |
| Power input | : 100-230V, 50/60Hz, single phase |

Process accessories

| | |
|---------------------------------|---|
| Metals sputtering | : Single magnetron source for 54mm diameter target |
| Available targets | : Au, Au/Pd, Cu, Fe, Cr |
| Sputter options | : Sputters oxidising metals (Aluminium) where turbo pump option specified |
| Carbon fibre evaporation | : Pulse deposition with selectable current and degas mode |
| Carbon rod evaporation | : Pulse deposition with selectable current and degas mode |
| Water cooled SEM stage | : Water cooled with bias function for 6 stubs |
| Rotary and planetary SEM stages | : Rotary stage for 6 stubs, planetary stage for 6 stubs |
| Rotary stage for R&D | : Rotary stage for substrates up to 100mm diameter |

| | |
|------------------------------------|--|
| BT300 | |
| Chamber | : Glass cylinder 300mm diameter x 150mm tall with implosion guard. Option for 200mm tall chamber |
| Rotary pump | : 12m ³ two-stage rotary pump. Option for dry scroll pump |
| Turbo pump option | : 62l/s compound turbomolecular pump with on-board controller |
| Ultimate vacuum (rotary pump only) | : 5x10 ⁻² mbar in <12 minutes |
| Ultimate vacuum (with turbo pump) | : 5x10 ⁻⁵ mbar in <20 minutes |
| Power input | : 100-230V, 60Hz/50Hz, single phase |

Process accessories

| | |
|-------------------------|---|
| Metals sputtering | : Single, or dual, or triple magnetron source for 54mm diameter targets |
| Available targets | : Au, Au/Pd, Cu, Fe, Cr |
| Sputter options | : Sputters oxidising metals (Aluminium) where turbo pump option specified |
| Rotary stage for R&D | : Rotary stage for substrates up to 100mm diameter (dual target), 150mm (triple target) |
| Planetary stage for R&D | : Planetary stage for uniformity on substrates up to 200mm diameter (triple target) |

| | |
|----------------------|--------------------------------------|
| Certification | : BT150 and BT300 carry the CE mark. |
|----------------------|--------------------------------------|

BT150-300 v1 11/2015
E&OE



HHV Ltd

Unit 14, Lloyds Court, Manor Royal, Crawley,
West Sussex, RH10 9QX, United Kingdom
Phone: +44 (0) 1293 611 898; Fax: +44 (0) 1293 512 277
Email : info@hhv ltd.com; Website: www.hhv ltd.com