

User manual

CCR Liberty

CU HW rev 1 5, HS HW rev 3 0, FW 2 11



Content

Introduction

Use of this manual

Responsibility of the CCR Liberty user

Documentation

User support

Technical data

Depth limits

Water temperature limits

CO₂ scrubber duration limit

Weight

Introduction

Use of this manual

This user manual is part of the CCR Liberty documentation.

The CCR Liberty is intended to be used exclusively by a trained person who is capable of fully understanding the instructions contained in this manual or is in the process of training with the CCR Liberty in a course accredited by the manufacturer. The training course prerequisites are set by cooperating agencies.

Responsibility of the CCR Liberty user

Strong emphasis was placed on reliability during the development of the CCR Liberty. Internal parts are individually separated to minimize the impact that a failure of any given part may have on the rebreather's basic functionality. Several systems have multiple backups. The logic behind the CCR Liberty is that the controls will never prohibit the start of a dive, even if malfunctions are detected. The system never locks out the diver; instead, the system will indicate the status of the unit in light of any damage if able to do so. When cave diving, the inability to submerge can mean not being able to return from a dive; therefore, the CCR Liberty does not impede submersion.

It is always the user's responsibility to decide whether he/she switches to a backup

apparatus or chooses to begin a dive with a partially malfunctioning rebreather.

A CCR Liberty user must accept the fact that diving involves risk. Following everything the user has learned by reading the CCR Liberty's technical manual and during their training on the rebreather can only reduce the risk. Diver safety is increased through by regular training, methodical education, and following good diving practices. Diving with a rebreather requires a far greater degree of discipline and awareness compared to diving with an open-circuit apparatus.

If you do not accept this risk and you are not a trained, careful, and disciplined diver, do not dive with the CCR Liberty.

The manufacturer does not bear any responsibility for the use of the CCR Liberty if the apparatus has been modified in any way that is not stated in this manual or in the technical guidelines issued by the manufacturer.

Documentation

Version

The technical documents are subjected to a process of continual development and improvement. Therefore, please regularly check the website at divesoft.com for updates.

This manual provides operating instructions for the hardware and software (firmware) version of the CCR Liberty written on the title page.

Technical guidelines

The manufacturer can issue technical guidelines. It is strongly recommended that the user regularly checks divesoft.com for new guidelines. Registered users will receive notifications by e-mail.

Document updates

The electronic form of the manual is always available in its complete, updated form. The electronic and printed forms of the manual may not be completely identical. In

case of insignificant changes (correction of minor typing errors, for example), only the electronic version is updated.

User support

Registered users are entitled to technical support. The extent of free support can be limited. The technical support department at Divesoft s.r.o. will provide limited support for potential and unregistered users. Prior to submitting a question, please familiarize yourself with the general principles of trimix rebreather diving and the CCR Liberty technical documents available for free

Technical data

Depth limits

The maximum depth for which the CCR Liberty meets the requirements of the Harmonized Standard EN 14143:2013 is 100 m.

Diluent / Max. depth

Air : 40 m

tmx : 21/35 66 m

tmx : 18/45 78 m

tmx (heliox) : 10/90 > 78 m

Additional depth limits depend on the diluent used, see section 3.2.5 Tank filling – Diluent.

All components are subjected to a pressure of 6 MPa (depth 600 m). The depth gauge is checked and calibrated to a pressure of 3.5 MPa (depth 350 m). EC Type-examination was performed to a simulated depth of 100 m.

Water temperature limits

The CCR Liberty is intended for use in water temperatures above 4 °C and below 34 °C

according to the requirements of EN 14143:2013 (Article 5.1).

The minimal temperature is determined through CO₂ scrubber duration tests, which are performed at 4 °C.

CO₂ scrubber duration limit

The maximum safe operating period of the sorbent is 168 min, determined by a test in accordance to EN 14143:2013 (Article 6.6.2). During the test, 1.6 l/min of CO₂ were added to the breathing loop with a ventilation rate of 40 l/min and an exhalation temperature of 32±4 °C; the unit was submerged in 4° C water to a depth of 40 m with a ppCO₂ of 5mBar.

The sorbent's actual maximum operating period can differ depending on the sorbent, temperature, depth, and the diver's physical effort.

Under normal conditions, scrubber duration ranges from 4 h in deep cold water with moderate work to 6 hours for a minimal working dive. For details see section 3.2.1 Sorbent service life.

Weight

The total ready-to-dive weight of The CCR Liberty (including scrubber), is approx. 37 kg.

For details see part 1.15 Weights of individual parts.

The recommended service intervals are at 1 year, 3 years and 5 years.

The servicing of the unit can only be performed by authorised service technician or technical centre.

Not performing services at regular intervals may result in voiding your warranty.

Section 1 - Technical design

Section: 1. Technical design

1.1 Basic schematic

1.2 Dive/surface valve

1.2.1 Inhalation valve

1.2.2 Exhalation valve

1.2.3 Mouthpiece

1.2.4 Usage with a full face mask

1.3 Corrugated hoses and accessories

1.3.1 Hoses

1.3.2 Attachment to the head

1.3.3 Connection to the breathing bags

1.3.4 Attachment of the DSV

1.4 Inhalation bag

1.4.1 Automatic diluent valve

1.4.2 Manual diluent bypass valve

1.5 Exhalation bag

1.5.1 Manual oxygen bypass valve 1.5.2 Overpressure valve

1.6 Oxygen tank

1.6.1 Tank

1.6.2 Valve

1.6.3 Reduction valve

1.6.4 Pressure reading

1.7 Diluent tank

1.7.1 Tank

1.7.2 Valve

1.7.3 Reduction valve and pressure reading

1.7.4 Backup regulator (optional)

1.8 CO₂ scrubber

1.9 Head

1.9.1 Control units

1.9.2 Direct measurement of ppO₂

1.9.3 Measurement of He content

1.9.4 Helium blind plugs

1.9.5 Pressure and depth measurement

1.9.6 Temperature measurement

1.9.7 Solenoids

1.9.8 Power supply

1.10 Visual display units

1.10.1 Handsets

1.10.2 Head-up display

1.10.3 Buddy display

1.11 Backplate and mounting

1.12 Harness

1.13 Buoyancy compensator

1.14 Ballast

1.15 Weights of individual parts

1. Technical design

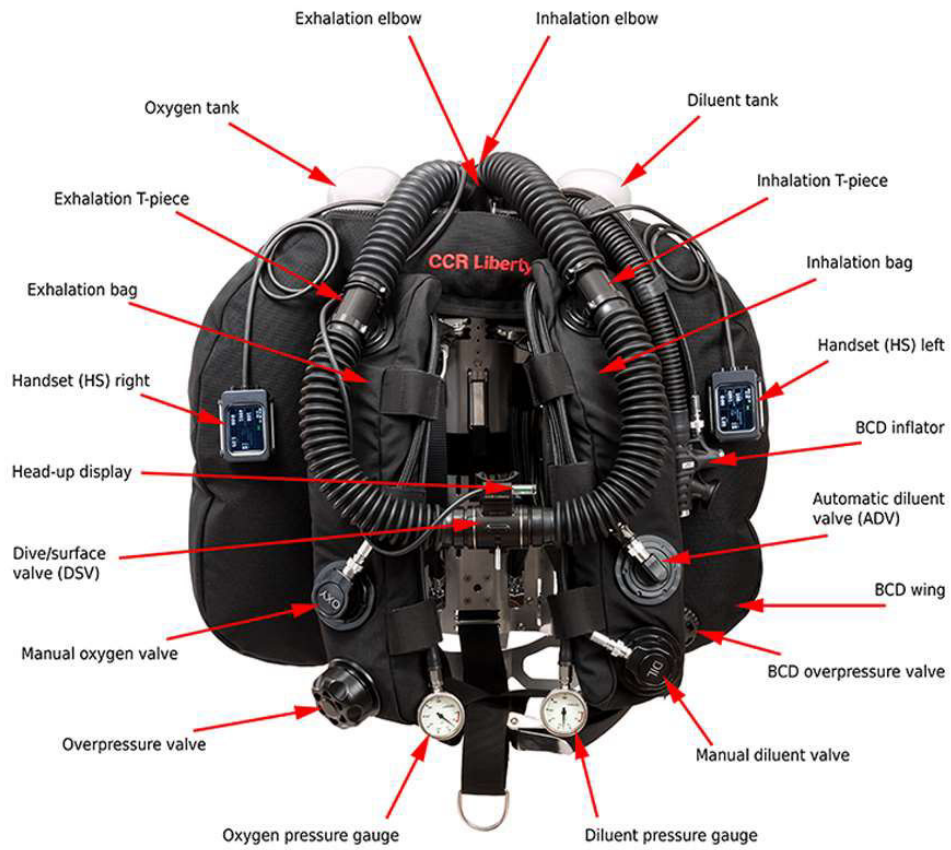

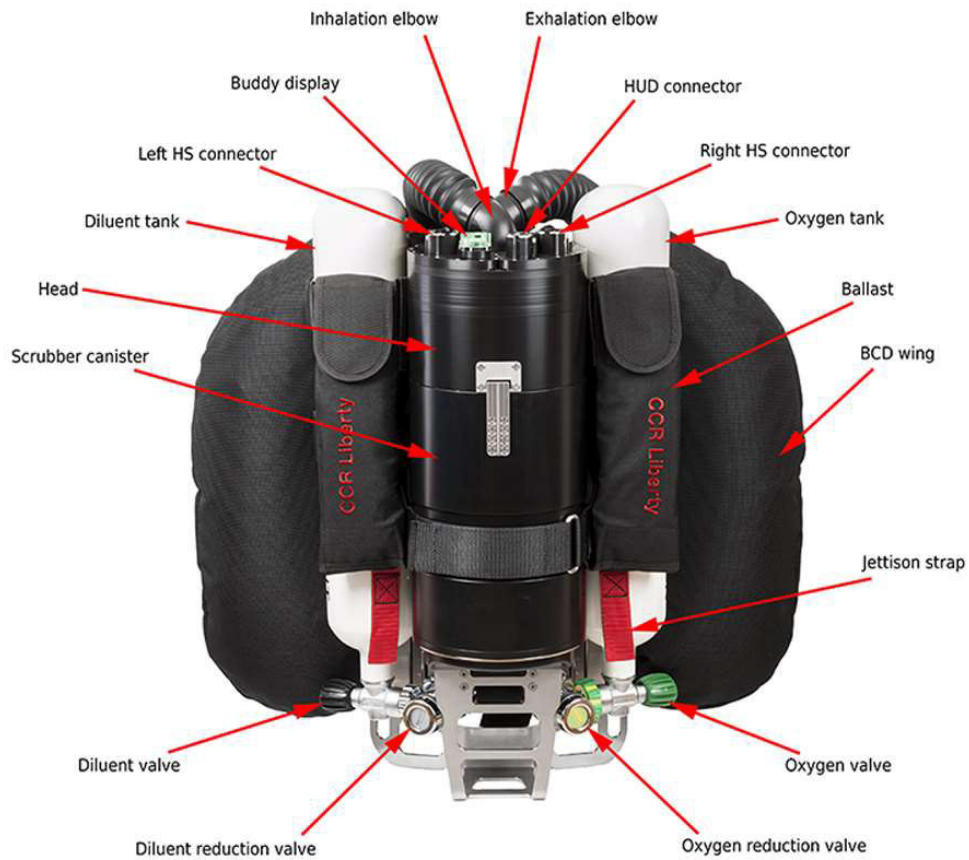

1.1 Basic schematic

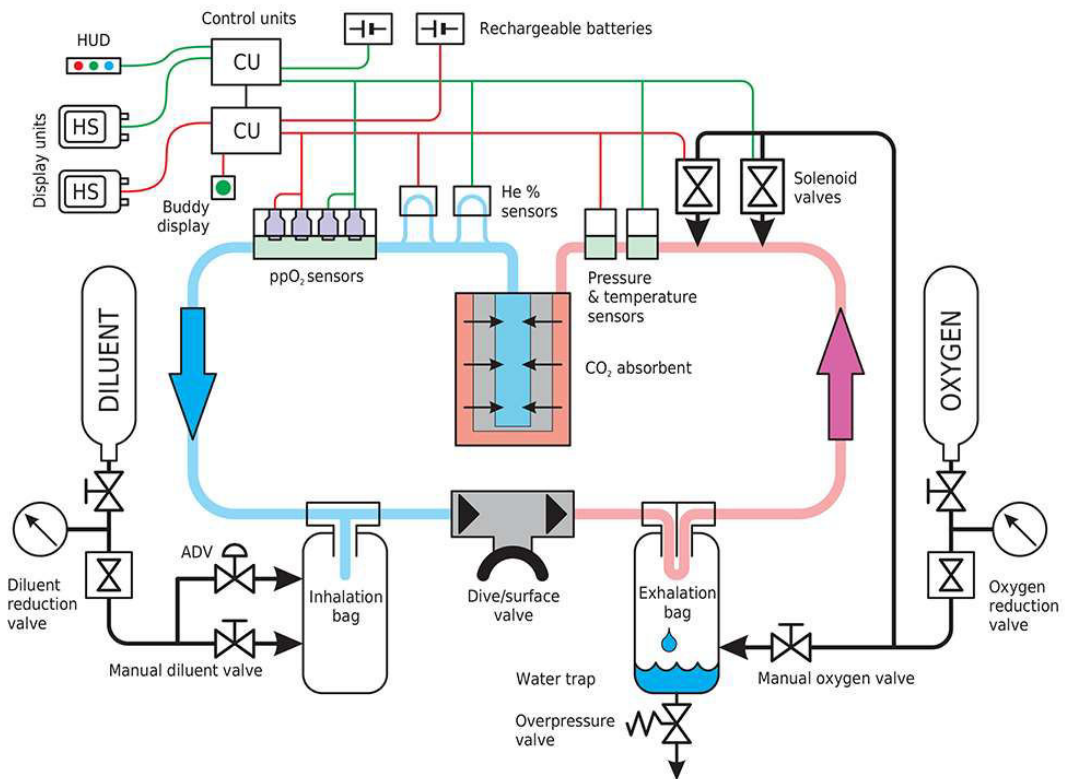

The principle of a rebreather involves in recycling the breathing mixture. Carbon dioxide is removed from the exhaled mixture and is again prepared for the next

inhalation after being replenished with oxygen. The composition of the breathing mixture changes continuously.

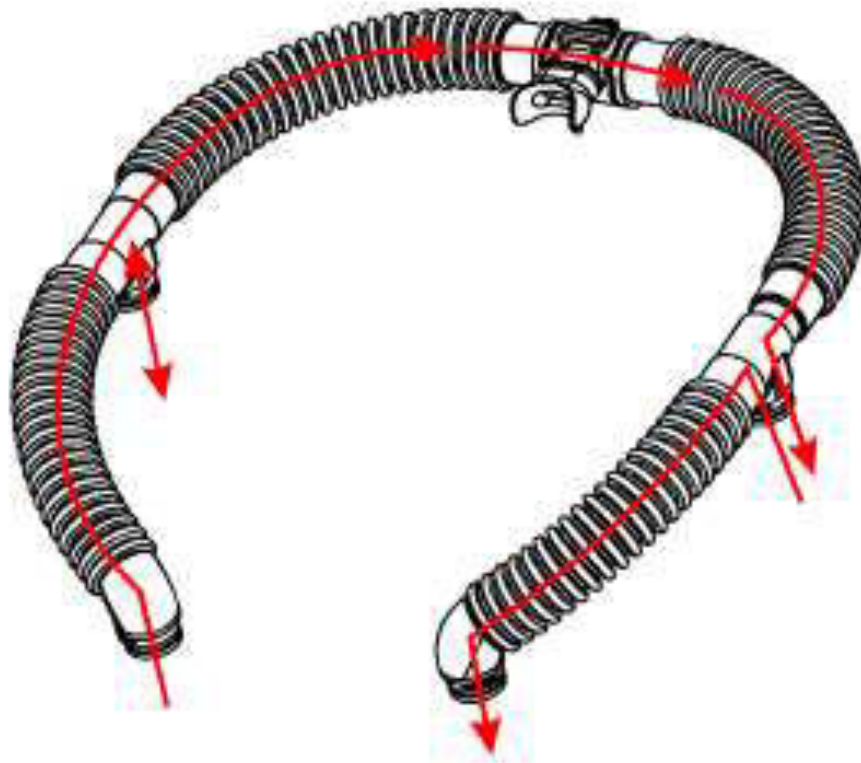

1.2 Dive/surface valve

The breathing mixture is delivered to the dive/surface valve (DSV) through the corrugated hose from the left. When inhaling, the mixture passes through the inhalation valve to the mouthpiece and then into the diver's respiratory tract. When exhaling, it passes through the exhalation valve into the corrugated hose on the right.

The direction of the mixture's flow is indicated on the DSV.

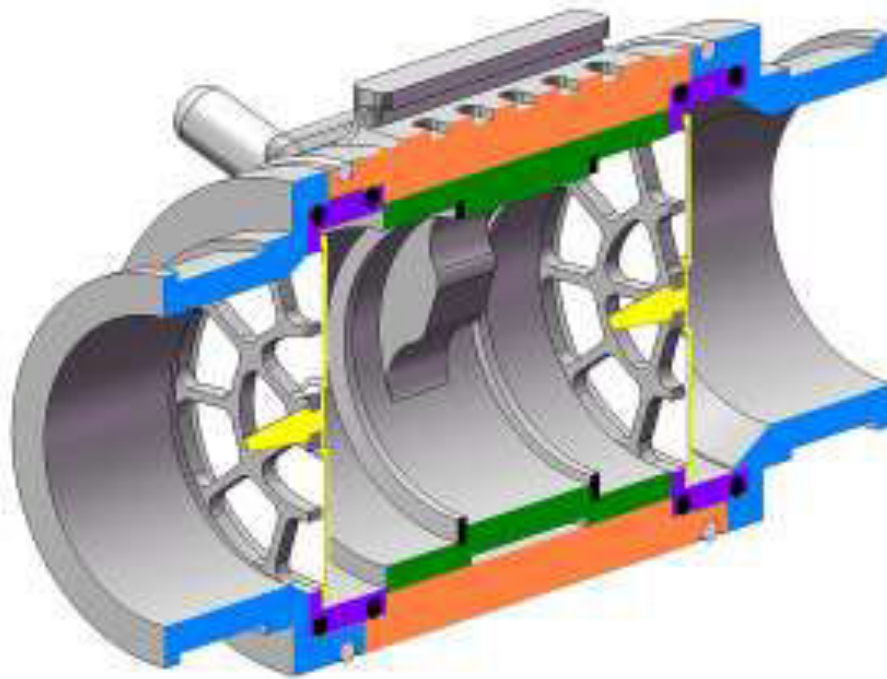

1.2.1 Inhalation valve

The inhalation valve ensures that the exhaled mixture does not backflow into the inhalation bag and is not repeatedly inhaled by the diver without the removal of carbon dioxide and the addition of oxygen.

The inhalation valve is situated within the connection of the left corrugated hose.

A similar mushroom valve can be found in the exhalation valve an open circuits's second-stage regulator.

This is one of the most critical components of the rebreather. It is, however, difficult to detect a malfunction in this part during a dive, and such a malfunction can lead to loss of consciousness.

1.2.2 Exhalation valve

The exhalation valve directs the exhaled mixture via the corrugated hose to the

exhalation bag. It prevents the diver from directly re-inhaling the exhaled mixture.

The exhalation valve is situated within the connection of the right corrugated hose.

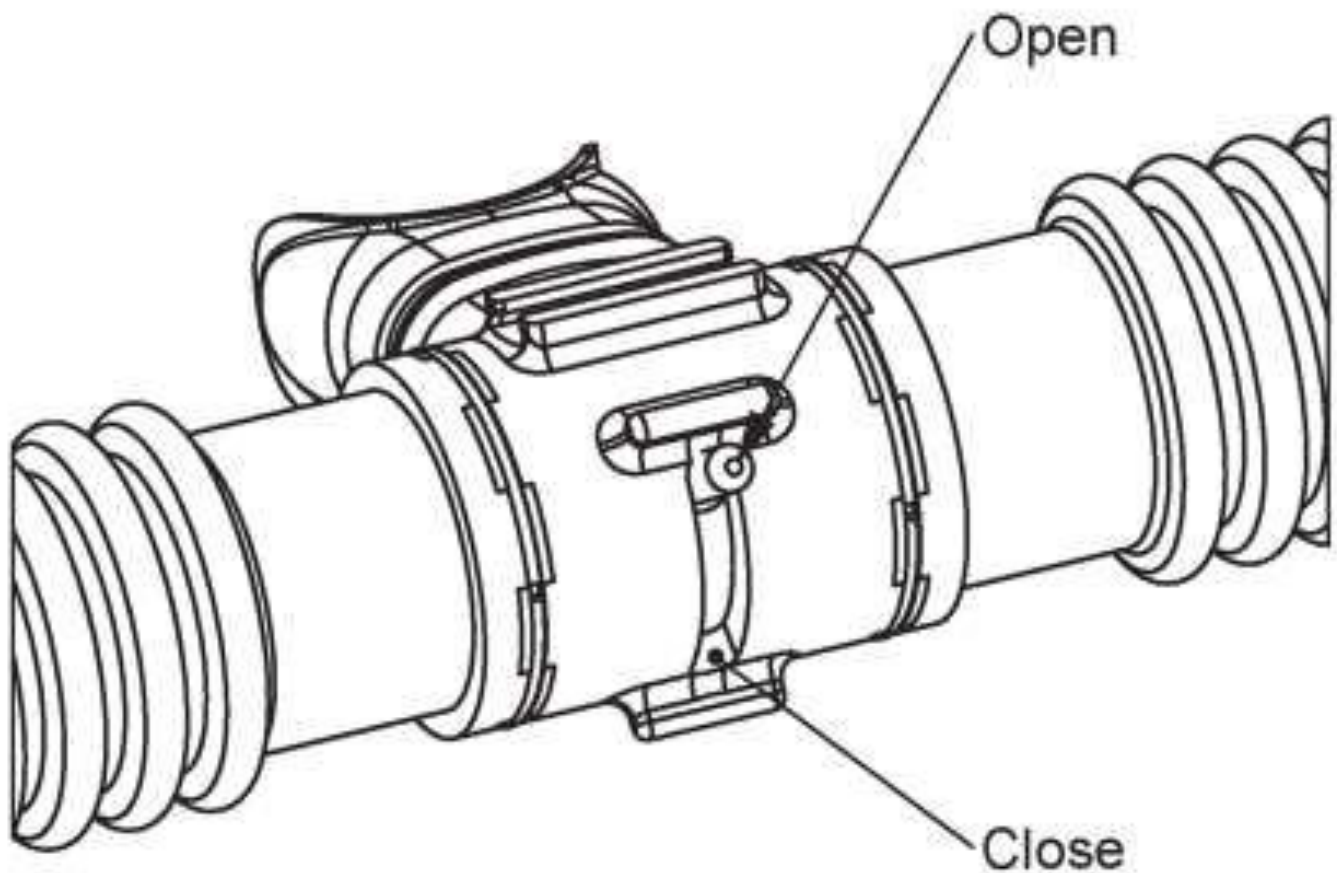

Closing the dive/surface valve

If the diver is in the water and not using the DSV, the DSV must be closed. Otherwise, the circuit will become flooded with water.

Closing the DSV is done by using the gate handle situated on the front part of the DSV. In the open position, the handle is put up; in the closed position, it is down.

1.2.3 Mouthpiece

Creating a tight seal around the rebreather's mouthpiece prevents water from entering into the circuit. The DSV and corrugated hoses function at a greater force than the regulator of an open-circuit apparatus. Therefore having, an anatomically suitable mouthpiece and proper clenching of the mouth is critical.

We do not recommend using a mouthpiece that can be shaped to the diver's bite after heating. This kind of mouthpiece restricts the movement of the lower jaw, which leads to unilateral stress and will rapidly exhaust the masseter muscles.

1.2.4 Usage with a full face mask

Even though the mechanical dimensions of the DSV would allow for the connection of a full face mask, it is not possible to switch an open-circuit mixture inlet with an inlet from a rebreather. One of the reasons for this is the necessity of defogging the visor.

Consult with the manufacturer regarding possibilities of connecting a full face mask to the rebreather. The use of such an apparatus will require procedures that deviate from this manual and from standard procedures taught in a course accredited by the rebreather's manufacturer.

1.3 Corrugated hoses and accessories



1.3.1 Hoses

The corrugated hoses are made of EPDM rubber. Compatible chemical agents must be used for cleaning and disinfection (see section 3.5.3 Cleaning and disinfection).

The corrugated hoses can be damaged if subjected to excessive stress.

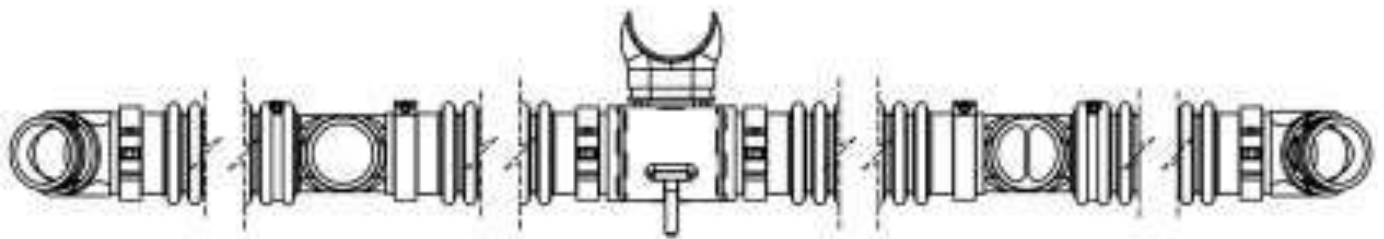

In particular, it is necessary to avoid perforation, cutting, and excessive wear. Avoid long-term deformation of the hoses when storing the unit. Do not treat the hoses like a hanger.

The corrugated hoses are one of the least durable mechanical parts of the CCR Liberty. Pay appropriate attention to protecting and maintaining them.

1.3.2 Attachment to the head

Unlike almost all other bayonet connectors on the CCR Liberty, the bayonet connector on the exhalation side has three protrusions. This design prevents incorrect

attachment of the hoses, since the inhalation side has only two protrusions.

Elbow on the exhalation side (left) and inhalation side (right).

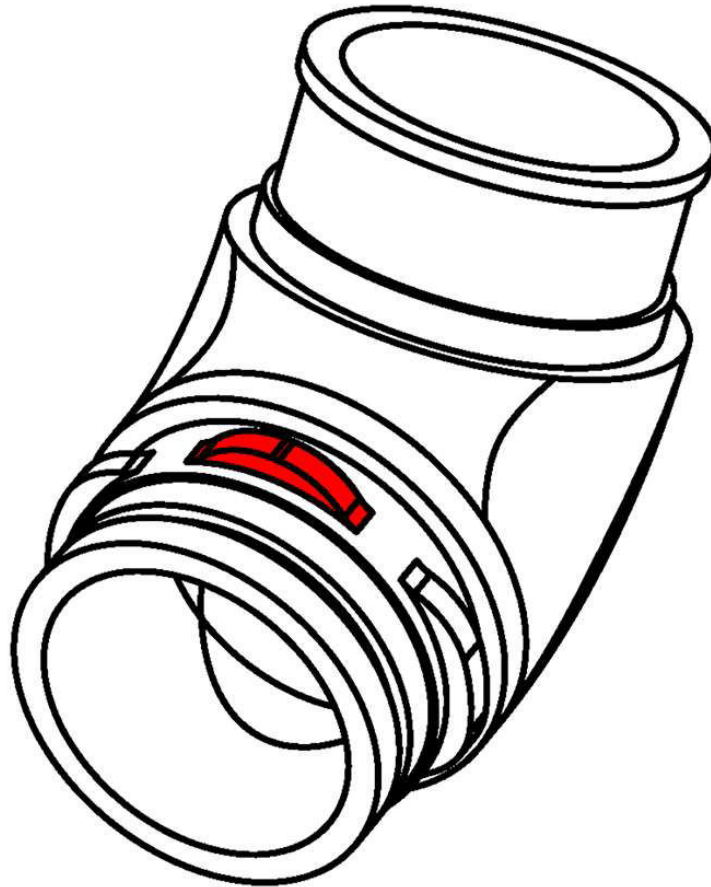

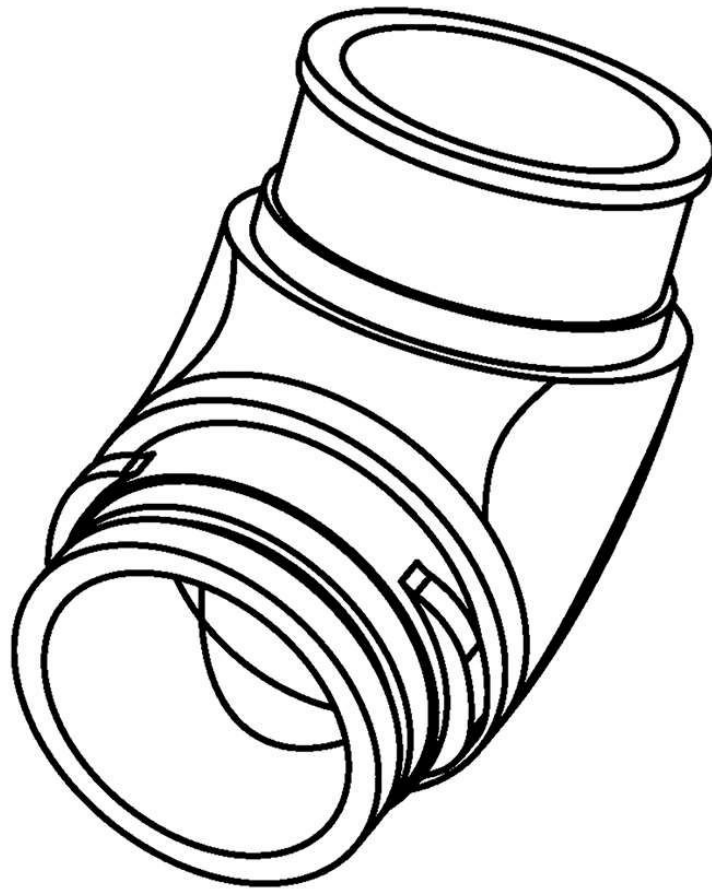

1.3.3 Connection to the breathing bags

The T-pieces have standard bayonet connections. On the exhalation side, the T-piece has a partition that directs any water that has entered the DSV to the exhalation bag and improves the blending of the mixture when oxygen is added via the manual bypass valve.

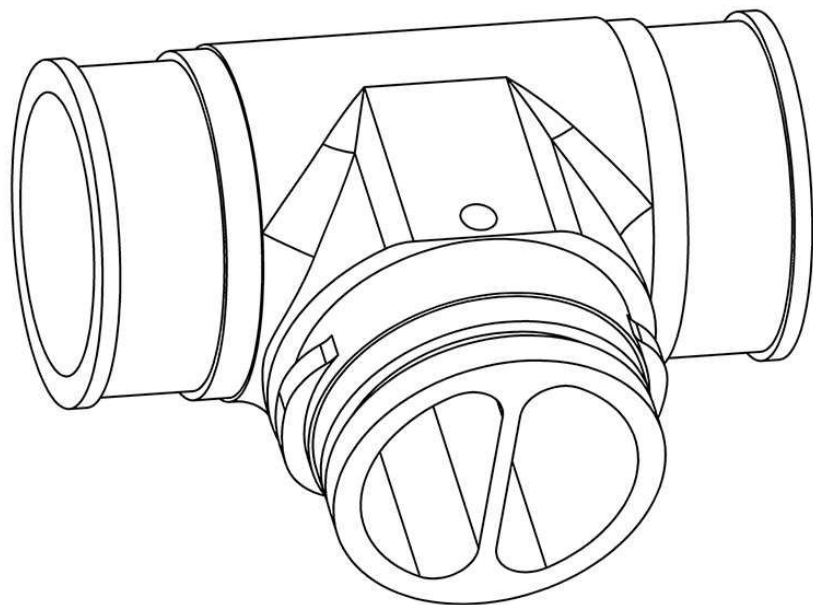

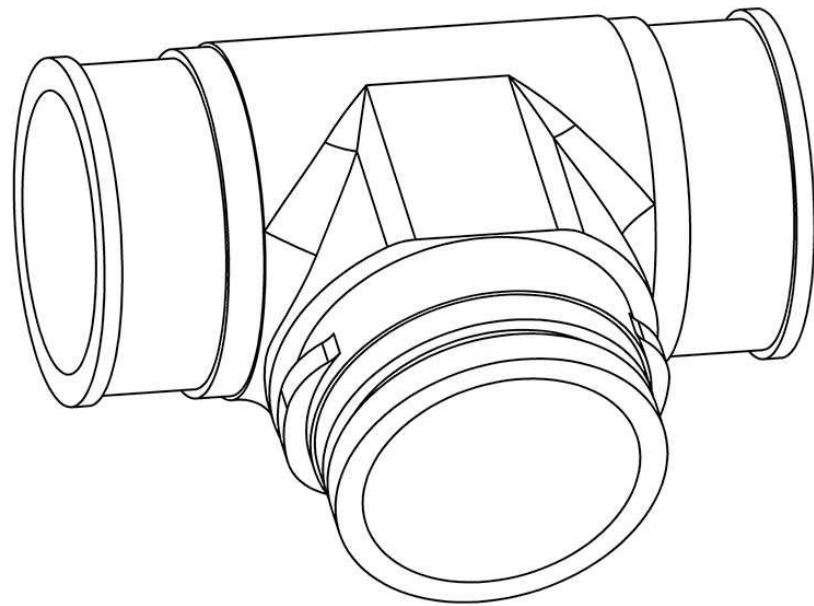

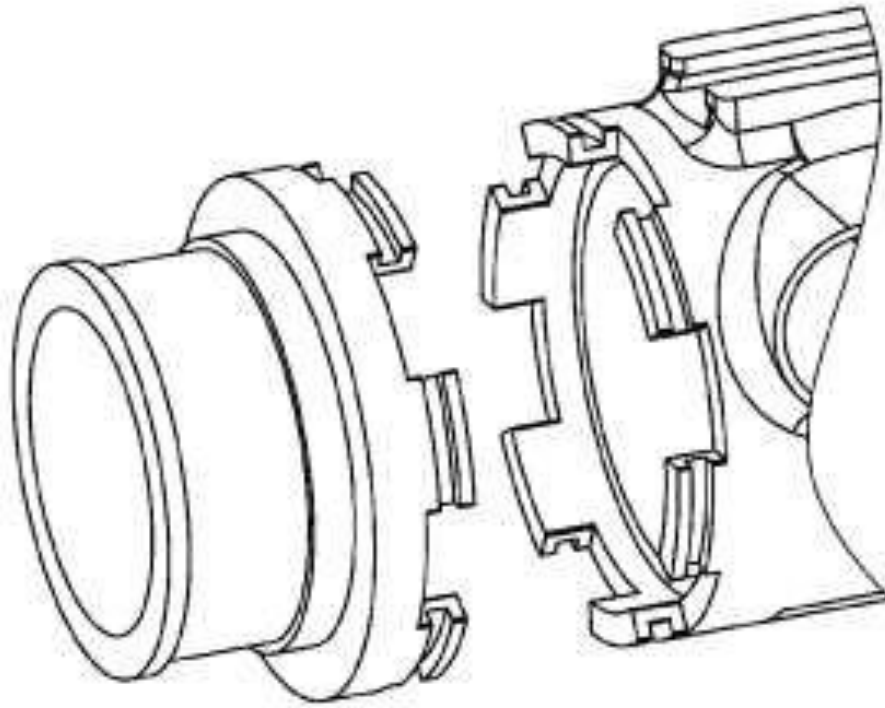

1.3.4 Attachment of the DSV

The DSV attachment to the corrugated hoses is done with axial teeth that fit together and are secured with a wire retaining ring.

The baskets of the mushroom valves are inserted into the connector. When handling the baskets, pay close attention to their correct orientation.

1.4 Inhalation bag

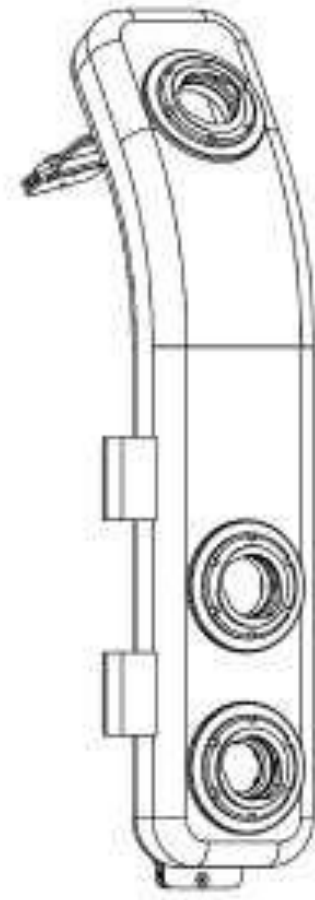

The inhalation bag is mounted on the left side of the harness (from the diver's perspective when wearing the CCR Liberty).

The external cover is made from a resilient textile, ensuring mechanical protection. The internal bag is made from polyurethane. It is connected to the breathing circuit with a T-piece via the upper bulkhead with a bayonet connector.

The inhalation bag is affixed to the harness with two stainless-steel buckles and is secured with Velcro flaps. It can be easily removed for cleaning, disinfecting, and other handling.

See also section 3.5.3 Cleaning and disinfection.

1.4.1 Automatic diluent valve

The automatic diluent valve (ADV) is mounted in the middle bulkhead with a bayonet connector.

When the volume of the inhalation bag decreases, the ADV is pressed, and diluent is automatically added to the breathing circuit.

The ADV can be closed by sliding the collar.

The sensitivity of the ADV can be decreased with an additional spring, which is included as a spare part.

1.4.2 Manual diluent bypass valve

The manual diluent bypass valve is situated in the lower bulkhead of the inhalation bag and is equipped with a bayonet connector.

The valve is attached to the low pressure (LP) hose with a seatec-style quick-release connector.

It is operated by pressing the center button.

The safety lock prevents diluent valve from accidentally falling out. Keep this information in mind when removing the valve.

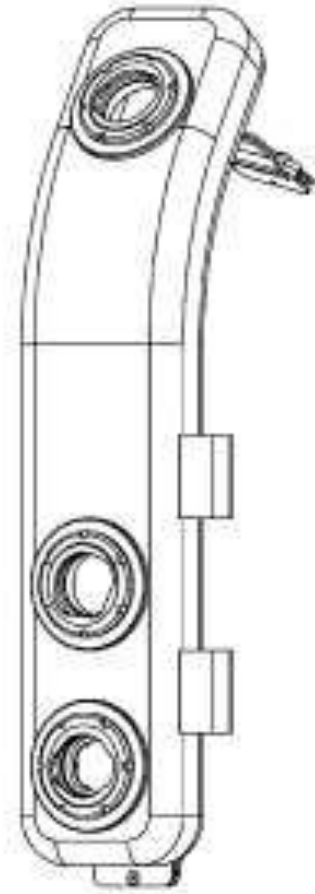

1.5 Exhalation bag

The exhalation bag is situated on the right side of the harness. It's design and the way it is connected to the harness and to the breathing loop are similar to that of the inhalation bag.

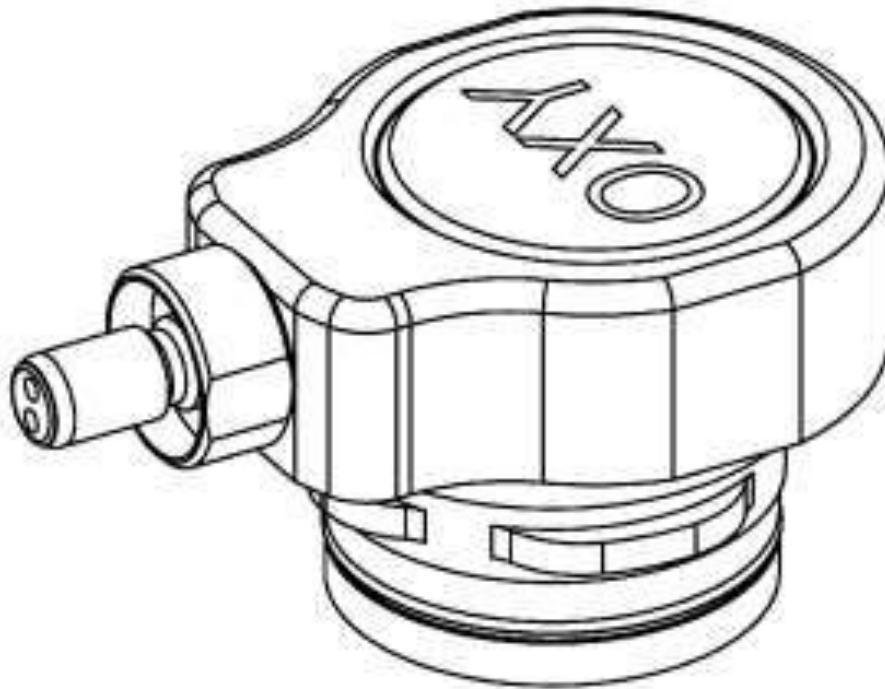

1.5.1 Manual oxygen bypass valve

The manual oxygen bypass valve is situated in the middle bulkhead of the exhalation bag and is equipped with a bayonet connector.

The valve is attached to the intermediate pressure hose with an oxygen quick-release connector.

This connector is like a standard seatec-style quick-release connector with a collar.

A standard connector cannot be connected to the oxygen quick release connector, though, it is possible to connect the oxygen hose to the normal connector.

Do not remove the collar from the oxygen connector as connecting the wrong gas to the wrong valve could potentially be dangerous. This is a requirement of the EN 14141 norm.

The bayonet connector on the oxygen bypass valve has three protrusions.

Use oxygen-compatible lubricant for maintenance of the oxygen bypass valve (**We recommend DuPont Krytox GPL-226**).

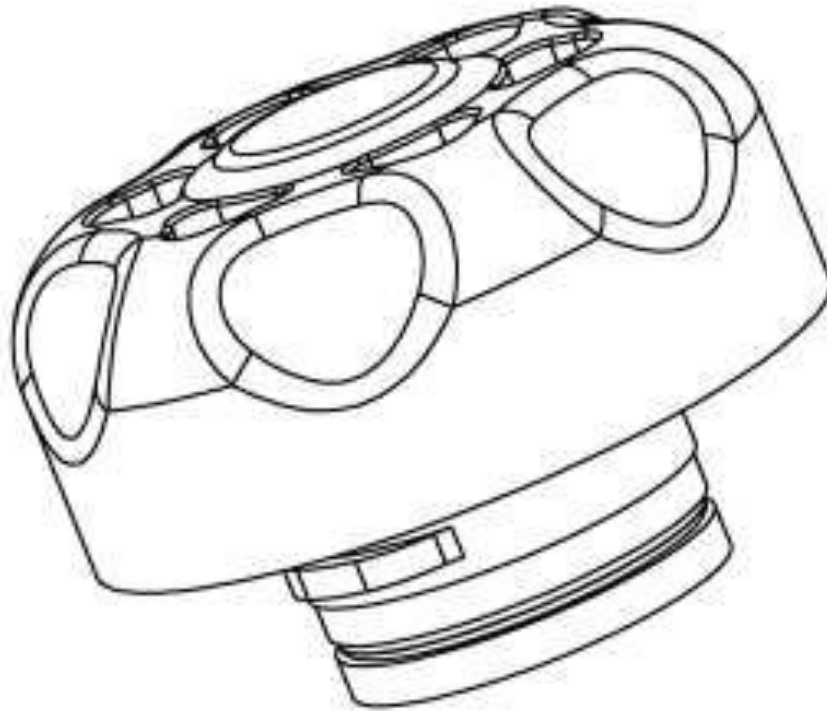

1.5.2 Overpressure valve

The overpressure valve (OPV) is mounted in the lower bulkhead of the exhalation bag and is equipped with a bayonet connector.

The required pressure is regulated via rotation. When set to a minimal pressure (by turning counterclockwise), the valve is opened; only a mushroom valve ensures minimal overpressure.

A safety lock prevents the OPV from accidentally falling out. To remove the valve push it in to unlock, and rotate in the direction of the arrows. Indicated on the valve.

1.6 Oxygen tank

1.6.1 Tank

The CCR Liberty uses a three-liter steel tank with 100 mm diameter and has a 200 bar filling pressure. The original 300 bar filling pressure of the tank was changed according to valid technical standards.

The tank is labeled OXYGEN and is situated on the diver's right side when wearing the CCR Liberty.





When connecting the oxygen tank to the unit, make sure the tank is in an upright orientation before tightening the handwheel on the oxygen first-stage regulator. Trying to straighten the cylinder when it is already screwed in will put tension on the threads and will be hard to remove without the help of tools.

For more information on filling, see section 3.2.5 Oxygen.

WARNING: The cylinders and valves are made of oxygen compatible materials and all components have been oxygen cleaned during their manufacture. However, unless assembled by a certified service technician, they cannot be considered oxygen clean.

1.6.2 Valve

The oxygen tank valve has a M26×2 200 bar outlet connection. The valve is not compatible with standard DIN valves to eliminate possible mix-up between oxygen and diluent bottles, this is a requirement of the EN 14141 norm.

1.6.3 Reduction valve

The CCR Liberty uses an Apeks DST4 first-stage regulator with a specially made low-pressure turret mounted on the backplate that serves as a lower tank-mounting point. A Velcro strap wraps around the middle of the tank to secure it to the unit.

The reduction valve is equipped with an intermediate-pressure safety overpressure valve.

1.6.4 Pressure reading

The oxygen pressure gauge is situated on the diver's right side; the HP hose runs through an opening in the backplate.

1.7 Diluent tank

1.7.1 Tank

The CCR Liberty uses a three-liter steel tank with 100 mm diameter and 230 bar filling pressure. The original 300 bar filling pressure of the tank was changed due to utilizing a 230 bar valve.

The tank is labeled DILUENT and is situated on the diver's left side when wearing the CCR Liberty.

For more information on filling, see section 3.2.5 Diluent.

1.7.2 Valve

The diluent cylinder valve has a DIN G 5/8" 230 bar outlet connection.

1.7.3 Reduction valve and pressure reading

The design is similar to that of the oxygen tank, only mirrored.

1.7.4 Backup regulator (optional)

The second stage of a regulator may be connected to the output of the diluent first-stage via a LP hose of an appropriate length. This regulator can be used as a backup if the diluent at a given depth is breathable (oxygen partial pressure between 0.16 and 1.6 bars).

Having the backup regulator connected to the diluent may be useful for sanity breaths and for prolonged switching to a backup apparatus.

However, it is advised to use the bailout only in special circumstances, such as when diving in extremely shallow water.

1.8 CO₂ scrubber



The CCR Liberty uses a radial scrubber. The breathing mixture flows from the outside to the center of the scrubber cartridge.

The scrubber apparatus consists of a scrubber cartridge inserted into a scrubber canister. A water trap is situated in the lower part of the canister.

The walls of the cartridges are fabricated with external and internal metal mesh. A metal disc presses down on the scrubber cartridge by means of a spring-loaded pressure plate. The pressure plate is fastened to the central tube with a retaining ring.

The scrubber cartridge capacity is approximately 2.5 kg of sorbent. The sorbent volume is approximately 2.82-2.99 l.

The service life and replacement of the sorbent are described on section 3.2.1 Replacement of CO₂ sorbent.



1.9 Head

The head is mounted on top of the CO₂ scrubber canister.

When mounting the head, push the scrubber-canister pin into the corresponding indentation on the lower part of head, pushing down to seal it.

If it is difficult to remove the head, place the rebreather on a hard surface with the pin pointing downwards, as shown in the illustration. Press down on the head and the scrubber canister with your hands.

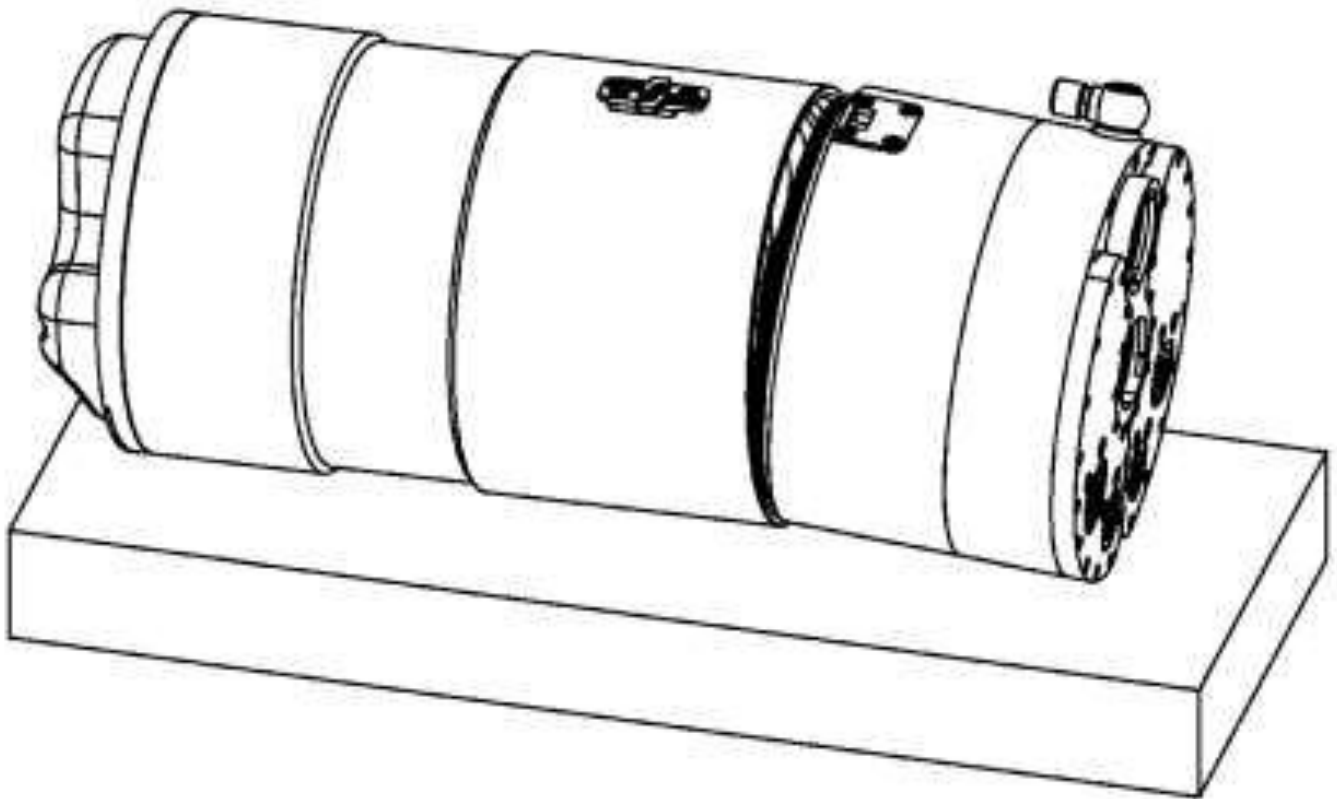

1.9.1 Control units

The control units (CUs) are independent, and each is connected to its own display unit or handset (HS). Each CU is equipped with its own power source, solenoid, temperature and pressure gauge, as well as its own, O_2 partial pressure and He concentration sensors

If one control unit fails, the other control unit takes over automatically.

CUs and HSs are independent computers communicating via a bus. Each handset displays the activity results of both CUs and is used to control both CUs. Each HS is powered by the corresponding CU. In the event both handsets malfunction, both, or one of the remaining CUs will continue to regulate ppO_2 according to the last adjusted setpoint.

If communication between the CUs breaks down, each unit will continue to control its own solenoid. The control algorithm is sufficiently robust to prevent any ppO_2 deviations from the allowed limits during dual, parallel regulation.

Connection to a personal computer

The memory of the operating protocols and content of the memory card can be read using a USB adapter connected to the handset connector as a mass storage device (like a flash drive). The connection to Windows, Mac, Linux, Android and iOS was tested, however there is no guarantee of compatibility with all operating systems and computers.

When using the USB connection, the control unit is powered from the USB port and, at the same time, the battery is being charged.

Each control unit contains the same dive logs; only one control unit needs to be connected to download the logs on a computer.

1.9.2 Direct measurement of ppO₂

To measure ppO₂ only use DIVESOFT R22D-type sensors. The usage of other sensors from other manufacturers is prohibited.

Two oxygen sensors are connected to each CU, and all sensors are located on the inhalation side. Both CUs have access to all four oxygen sensors and are continually exchanging data.

The diver can manually exclude a sensor from operating and can also choose when to reinclude it. Choosing to manually exclude a sensor always has priority over an automatic detection of a faulty sensor. If all sensors are excluded, the CCR Liberty can be switched to a backup algorithm with calculates the partial pressure of oxygen indirectly based off the measured the He content (assuming the used diluent contains >20% He).

Circulation of the mixture in the breathing loop is necessary for the measurement accuracy. If the user does not breathe from the rebreather, the mixture surrounding of the oxygen sensors can have a different proportion of oxygen than in the breathing loop. Thus, the displayed data can be inaccurate.

A similar situation can occur in the event of a rapid descent when a larger amount of diluent is added, or when the setpoint is changed to high, and the ppO_2 in the loop is progressing to the new level.

The sensors are constantly being automatically evaluated. The ppO_2 measured by one sensor is always compared to the average reading of the other sensors. This way, each individual sensor is constantly being cross-checked and monitored for possible deviations. If the average deviation of the sensors exceeds 0.1 bar, the system will automatically exclude the sensor that deviates most from the average.

Only one sensor can be automatically excluded at a time, and only a total of two sensors can be automatically excluded. There will always be at least two sensors that the diver has to evaluate themselves. This procedure is described in section 3.4.4 Monitoring of devices.

WARNING: Sensor exclusion works on the principle of a mathematical algorithm. Despite the efforts of developers to find the ideal risk-control solution, there is still a chance that the excluded sensor could be the only functional one. Always verify your oxygen sensors.

Refer to the chapter "Oxygen sensors" on how to handle and maintain your sensors.

1.9.3 Measurement of He content

The helium concentration is determined by the velocity of sound in the mixture. The He concentration sensors are connected to the inhalation side.

A pressure drop caused by the circulation of the mixture in the breathing loop allows the gas to pass through the sensor.



If the user does not breathe from the rebreather, this process will not occur, and the sensor reading may be inaccurate.

If the utilized diluent contains $>20\%$ He and its composition is known, the He-concentration measuring function can be used to reverse find the concentration of oxygen in the mixture based on the fact that the ratio of inert gases remains constant (process according to patent no. 303577).

This principle of measuring the oxygen concentration (and its subsequent automatic conversion on the basis of the known ambient pressure to partial pressure) is used as the backup method of measuring ppO_2 in case all electrochemical ppO_2 sensors malfunction.

Oxygen measuring using helium sensors must be manually turned on in Setup / Faulty sensors / pO_2 source. This method is intended for use only in emergency situations. If possible, use a bailout apparatus.

The use of helium sensors also depends on the CCR Liberty's settings. For the helium sensor function, the "TMX only" must be selected by going to Menu / Setup /

Preferences / He Measurement.

For proper functioning of helium sensors, the sensors must be calibrated regularly. Refer to Helium sensor calibration (see section 3.2.7) for the calibration procedure.

Always keep your helium sensors dry to ensure their long lifetime and functionality (see also section 3.5.1 Immediately after surfacing).

Do not disassemble the sensors, as this may result in irreparable damage.

WARNING: Do not remove the helium sensors from the unit, even when faulty. Their removal will “short -circuit” the scrubber, which will not be able to filter CO₂ from the breathing mixture.

1.9.4 Helium blind plugs

Included in your CCR Liberty are two helium sensor “blind plugs”. These plugs are designed to act as a spacer so that the user can remove the high-fidelity sensors. The Divesoft helium sensors are highly sensitive to moisture and can be easily corrupted if the moisture is not removed through proper ventilation. It is highly recommended to use our accessory head fan during post dive procedures to remove moisture that could collect within the sensors during diving.

The purpose of these plugs is so that the helium sensors can be removed when the user is not diving with a helium mix. It is recommended that when the user is not diving with a helium gas mixture the user should use the helium blind plugs instead.

To install the Blind plugs:

- First, take a hex key and remove the oxygen cells block.
- Once the block is removed then take hex key and remove the hex screw within helium sensor securing sensor to Liberty head.
- After screw is completely removed then firmly grasp helium sensor and gently remove sensor, take care as to not twist sensor upon removal.

- Then install the blind plug in the identical orientation as the helium sensor then secure with a hex screw, always be sure to use **only two fingers** for tightening screw and **do not over tighten screws**.
 - Repeat this process for opposite side helium sensor.
 - Once both blind plugs are installed and hex screws properly secured then reinstall oxygen cells block, take care as to not over-tighten any screws.
 - Place helium sensors in a labeled small bag and properly store them in a climate controlled area to use best practices for your rebreather sensors. They are designed for extreme conditions of rebreather diving, but in order to guarantee their life, they must be properly cared for.
 - During your pre-dive operations when using the blind plugs, the Liberty will show an error – sensor missing. Though the helium sensors are being disabled because the blind plugs are installed. This is expected and will not have any effect on diving operations.
 - If diving with trimix or other helium based mixtures, it is highly recommended that the Blind plugs be removed. And the high-fidelity helium sensors be installed into the Liberty head. Be sure to properly calibrate the sensors on air. Once the sensors are calibrated, check the Setup / Preferences if He measuring is set to “TMX only”. This will guarantee that you have redundant ppO₂ measurement and proper helium measurement in your Liberty rebreather system.
-

1.9.5 Pressure and depth measurement

Each of the CCR Liberty's control units uses dual pressure sensors. The first sensor intended for measuring low pressure is used for determining sea level, for calibrating of the ppO₂ sensors, and for improving the accuracy of depth data in shallow water.

The second sensor is intended mainly for measuring hydrostatic pressure. The maximum scope of the sensor corresponds to the depth of 300 m.

1.9.6 Temperature measurement

The temperature in the breathing circuit is measured by temperature sensors within the pressure sensors. The water temperature sensors are situated in the handsets.

Temperature data serves primarily to supplement the accuracy of other sensor measurements. The water temperature shown on the HS display is only an approximate reading.

1.9.7 Solenoids

The control units communicate with each other and, in normal circumstances, open the solenoid valves, which supply oxygen to the breathing circuit.

The solenoids are opened alternately left – right in a six-second interval. The solenoid opening is indicated in the dive mode by the “=” symbol in the left or right bottom corner of the handset screen.

1.9.8 Power supply

The CCR Liberty uses two Li-Ion batteries, one to power each control unit. The minimum service life of Li-Ion batteries is six months. The typical service life of the batteries is two years.

See also section 3.2.6 Battery charging.

The battery compartments are pressure resistant. If overpressure is formed inside of a battery compartment because of battery malfunction or helium diffusion, then an overpressure valve will release excess gases out of the rebreather and into the surrounding water.

Battery specification:

Type: Li-Ion

Voltage: 3.6V

Capacity: 5.7Ah

1.10 Visual display units

1.10.1 Handsets

The handsets provide the CCR Liberty's user with comprehensive information on the rebreather's status and the course of the dive. All functions of the control units are controlled using the handsets.

The functionality of both handsets is identical. Each handset controls both CUs simultaneously. In the event of a malfunction of one handset, the diver simply uses the other handset. During a dive, it is possible to set a different display mode on each handset.

For more information on handset operation, see section 2 Control-unit operation.

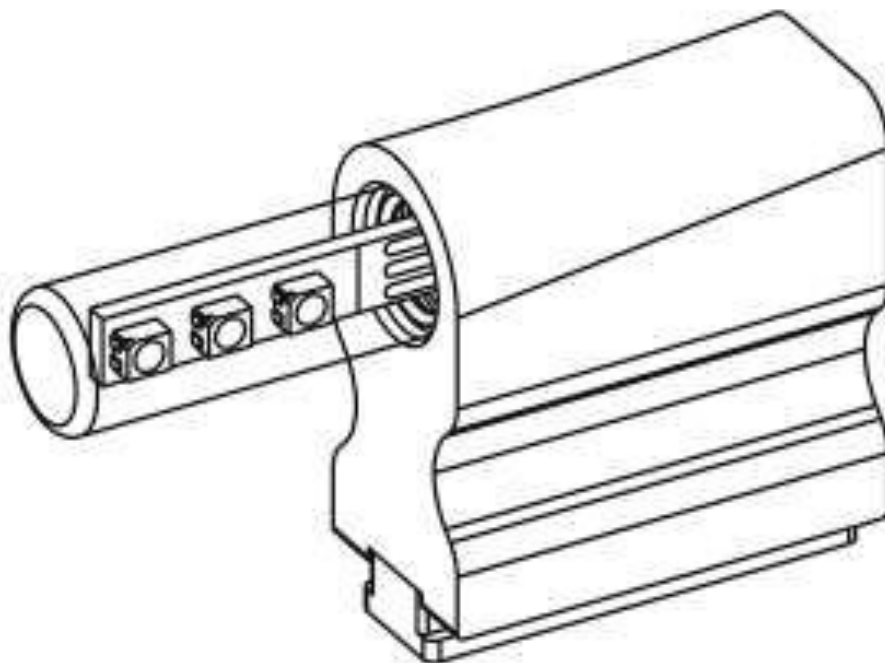

1.10.2 Head-up display

The head-up display (HUD) shows the current partial pressure or CCR error status

during the dive.

Other statuses are displayed in standby mode, during charging, and when the unit is connected to a computer.

If you are not entirely sure what the HUD is displaying, check the parameters on the handset display. Always check the HS if the HUD displays a warning (outer LED blinks red) or an alarm (all three LEDs flashes red four times).

See the following table for the various HUD signals.

The brightness of the HUD can be adjusted using Setup / Preferences / Indication / HUD bright. Changing the brightness of the display is only applied in dive mode. In Surface mode, it is not affected.

1.10.3 Buddy display

The buddy display (BD) shows whether the values of the partial pressure of oxygen are within the range that is suitable for breathing or if an error situation has occurred. The displayed information is intended for the diving partner of the CCR Liberty's user.

Prior to diving, the user of the CCR Liberty must familiarize his/her diving partner with the buddy display's functionality and agree on the emergency procedure to be carried out in the event that the buddy display indicates an error situation.

See the following table for the various buddy-display signals.

HUD and buddy-display signals

HUD and buddy-display signals

Mode	Event / state	HUD signals			BD signals
		LED 1	LED 2	LED 3	
Startup	Initializing components	Binary coded service numbers			
ppO ₂ in dive mode ¹ (bar; standard)	ppO ₂ < 0.16	• red blinking		• red blinking	• red blinking
	0.16 ≤ ppO ₂ < 0.20	• red blinking		• red blinking	• red
	0.20 ≤ ppO ₂ < 0.25	• red blinking		• red blinking	• green
	0.3		• 7× blue flash		• green
	0.4		• 6× blue flash		• green
	0.5		• 5× blue flash		• green
	0.6		• 4× blue flash		• green
	0.7		• 3× blue flash		• green
	0.8		• 2× blue flash		• green
	0.9		• 1× blue flash		• green
	1.0		• green		• green
	1.1		• 1× green flash		• green
	1.2		• 2× green flash		• green
	1.3		• 3× green flash		• green
	1.4		• 4× green flash		• green
	1.5		• 5× green flash		• green
	1.6		• 6× green flash		• green
	1.65 < ppO ₂ ≤ 2.0	• red		• red blinking	• red
	ppO ₂ > 2.0	• red		• red blinking	• red blinking
Dive mode alarm		• 4× red flash	• 4× red flash	• 4× red flash	no change
Standby (switched off from menu)	Standby		• slowly flashing		• slowly flashing
	Charging	• 1. red	• 2. red	• 3. red	• red
	Charger connected but no power supply	• red blinking			• red blinking
	Fully charged	• green	• green	• green	• green
	Charging failed	• red blinking	• red blinking	• red blinking	• red blinking
Mass storage mode (USB adaptor connected)	Reading	• green	• orange		• green
	Writing	• red	• orange		• red intensive
	No action		• orange		
Download firmware	Connected	• purple	• purple blinking	• purple	
	Downloading		• purple	• purple	

¹ Indicated ppO₂ value in the range ±0.05 bar

Color blind mode

If you cannot distinguish blue and green LED lights, check “Color blind mode” in Setup / Preferences / Indication. Signals for $1.05 \leq \text{ppO}_2 \leq 1.65$ will be changed according the following table:

ppO ₂ in dive mode ¹ (bar; color blind)	1.1	• 1× green flash		• 1× green flash
	1.2	• 2× green flash		• 2× green flash
	1.3	• 3× green flash		• 3× green flash
	1.4	• 4× green flash		• 4× green flash
	1.5	• 5× green flash		• 5× green flash
	1.6	• 6× green flash		• 6× green flash

¹ Indicated ppO₂ value in the range ±0.05 bar

1.11 Backplate and mounting

The method of mounting the CCR Liberty on the diver's body is based on the backplate and harness common among wing-type buoyancy compensators used in technical diving.

The body of the rebreather, comprised of the scrubber canister and the attached head is mounted to the backplate with a cam. The cam lever cannot be released when the diver is wearing the rebreather.

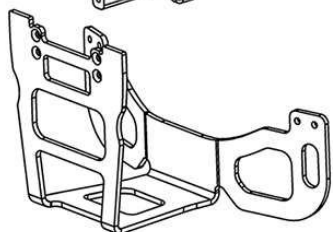
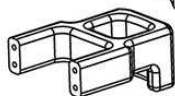
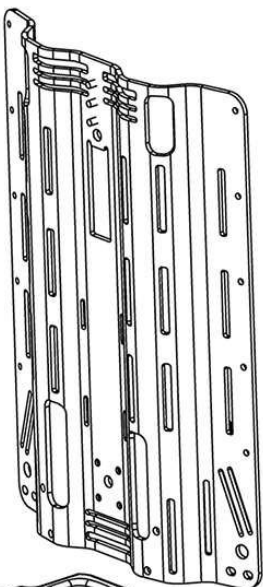

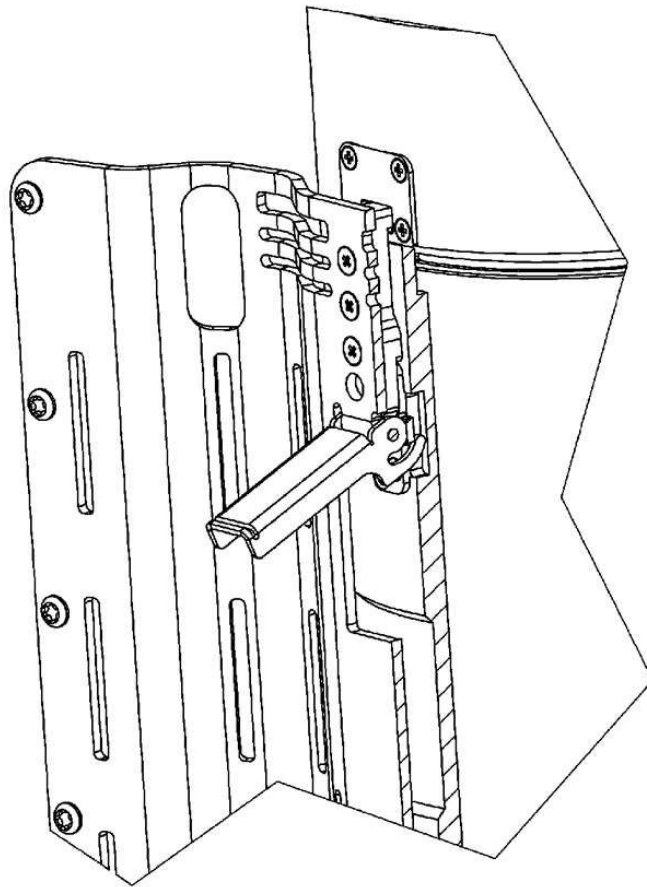

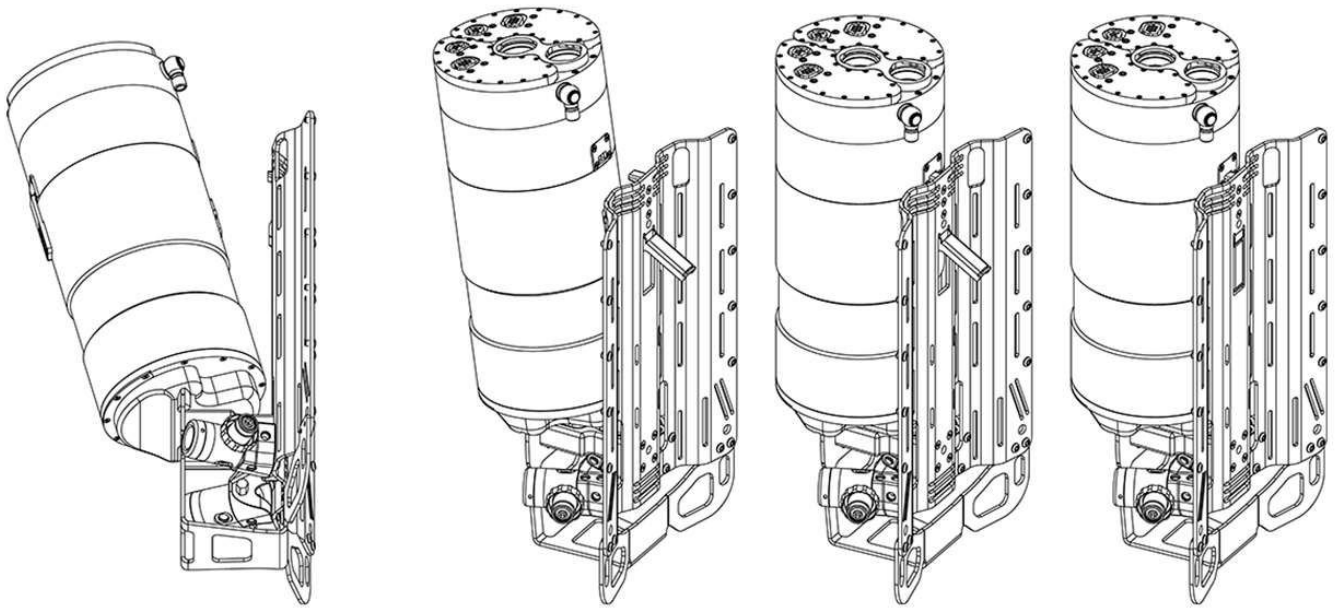

The CCR Liberty's integrated stand, which serves as a lumbar support, is intended for setting the rebreather on a hard, level surface with sufficient rigidity. Always secure the standing rebreather to prevent falling.

If needed, it is possible to remove the CCR Liberty's backplate, and use it with a harness for open-circuit diving. The backplate enables the attachment of a twin-set (two tanks firmly connected with stainless steel bands) commonly used in technical diving, as well as attachment of a single tank.

When mounting the CCR Liberty onto the backplate, set the bottom of the scrubber cannister into the protrusion in the rebreather stand.

1.12 Harness

The backplate is equipped with a harness that is to ensure proper system functioning. Do not change the way was intended to be used. If you do try to take the harness out, record exactly how it is threaded to prevent an interference with the functionality of the whole system.

It is necessary to adjust the harness to ensure a proper fit. Adjust the harness without the mounted scrubber canister, head, corrugated hoses, and breathing bags.

Adjust the length of the shoulder straps to where three fingers can easily fit under the straps at the collar-bone level.

The chest D-rings should be as low as possible, while still allowing you to cross your arms over your chest comfortably. The D-rings should be high enough for you to reach the left ring with your left thumb and the right ring with your right thumb. The D-ring on the left side of the waist strap should be roughly on your hip.

Adjust the length of the left part of the belt strap so that it passes through the eye of the crotch strap with approximately 5 cm (strap width) still remaining between the ring and the eye. Adjust the right part so that the strap is slightly tight. If you shorten a strap, leave sufficient room for different suits or a possible change in body dimensions. After shortening, it is necessary to deburr the ends of the straps by heat sealing them with a cigarette lighter or candle. Do this carefully to avoid forming a hard surface on the strap ends.

Adjust the length of the crotch strap so that it lies closely against the body but does not dig in. Set the position of the rear D-ring as low as possible but high enough so that it does not place pressure on the buttocks when swimming. The rear D-ring should be within the diver's reach. Test the exact position of the rear D-ring in the water with the complete apparatus.

1.13 Buoyancy compensator

The CCR Liberty uses a wing-type buoyancy compensator (BCD) with a displacement of 200 N. The compensator's design and materials are very durable and even suitable for cave and wreck diving.

The wing has a two-ply design. The internal bladder is made of high-frequency-welded Cordura 560 fabric with PU coating. The wing's external cover is made of Cordura 2000 fabric.

The wing is attached with screws along the edge of the backplate.

To correctly position the inflator, pass the low-pressure hose through the rubber ring on the corrugated hose, then through the rubber ring on the shoulder strap and finally through the second rubber ring on the corrugated hose. Do not skip either of the rings on the corrugated hose; upon disconnecting the quick-release connector from the inflator, it could move far enough back to where it is hard to find or reach.

The buoyancy compensator is not a life preserver. It does not maintain the diver in a face-up position. It is not designed to hold the diver's face above the surface should he/she become unconscious or immobile.

1.14 Ballast

The ballast system is composed of two pouches positioned on the sides of the scrubber canister and are attached to the tanks. In the lower part of the pouches, there is a loop through which the attachment strap of the rebreather body is passed. The internal pouches, which contain the individual weights, are inserted into the external pouches. The upper flap of the external pouch is intended for inserting weights before a dive and removing them after. For emergency jettisoning of ballast, pull the red strap on the lower part of the pouch. This will open the external pouch and will release the internal pouch containing the ballast.

For regular ballast removal, do not use the method for emergency jettisoning. This could lead to excessive wear of the Velcro.

A diver in a dry suit typically needs 2×4 kg of ballast. Proper ballast weight and distribution is a subject covered in the CCR Liberty diver course.

1.15 Weights of individual parts

The listed weights are merely an indication. The weight of the parts of each apparatus may vary.

Backplate with the wing, harness and hoses, without counterlungs	10.68 kg
Weight pockets (without weights)	0.43 kg
Counterlungs incl. all valves.....	1.86 kg
Tank with valve, empty	5.44 kg
Corrugated hose, complete	1.11 kg
Scrubber body and cartridge, without sorbent	3.76 kg
Head incl. handsets, HUD and BD	4.59 kg
Charger with cable	0.09 kg
Supplied accessories and small parts (without chargers)	1.00 kg
Peli Stormcase iM2975	10.30 kg
Oxygen 3 l at 200 bar	0.84 kg
Diluent (air) 3 l at 300 bar	0.91 kg
Sofnolime	2.50 kg
Energy stored in batteries	4.16×10 ⁻¹¹ kg

[< Previous page / Introduction](#)

[> Next page / Section: 2. Control-unit operation](#)

Section: 2. Control-unit operation

2.1 Control elements

2.1.1 Surface mode inputs

2.1.2 Dive mode inputs

2.1.3 Language

2.2 Switching on the unit

2.2.1 Activation

2.3 Surface mode

2.3.1 Entering surface mode

2.3.2 Surface mode primary screen

2.3.3 Surface mode O₂ sensors screen

2.3.4 Switching to other modes

2.3.5 ppO₂ control in surface mode

2.4 Setup

2.4.1 Editor use

2.4.2 Setpoints

2.4.3 Mixtures

2.4.4 Decompression

2.4.5 Alarms

2.4.6 Preferences

2.4.7 Calibration

2.4.8 Faulty sensors

2.5 Dive mode

2.5.1 Detailed screen

2.5.2 Synoptic screen

2.5.3 Big Screen

2.5.4 Dive profile screen

2.5.5 Sensors screen

2.5.6 TTS Screen

2.6 CCR mode

2.6.1 Entering CCR mode

2.6.2 Switching to other modes

2.6.3 ppO₂ regulation

2.6.4 Decompression

2.6.5 Specific handset control

2.7 Manual CCR mode

2.7.1 Entering manual CCR mode

2.7.2 Switching to other modes

2.7.3 ppO₂ regulation

2.7.4 Decompression

2.8 Bailout OC mode

2.8.1 Entering bailout OC mode

2.8.2 Switching to other modes

2.8.3 Mixture

2.8.4 Decompression

2.8.5 Specific handset control

2.9 Ascent plan

2.10 Setup in Dive mode

2.11 Games

2.11.1 Sokoban

2.11.2 Snake

2.12 List of pop-up alarms and notifications on CCR Liberty

2.12.1 Critical priority

2.12.2 High priority

2.12.3 Medium priority

2.12.4 Notifications

2. Control-unit operation

2.1 Control elements

All electronics in the CCR Liberty are controlled via the handsets.

The following inputs and combinations are distinguished by:

- Press upper key
- Press lower key
- Press both keys
- Long press upper key
- Long press lower key
- Long press both keys
- Coded key press (press both keys, then release one key and press it again, then release both keys)
- Tilt the HS away from yourself
- Tilt the HS toward yourself
- Tilt the HS to the left
- Tilt the HS to the right

– Tap the display glass

– Shine a light on the display

“Long press” means pressing the key for more than 2.5 seconds. The key-press operation can be terminated by releasing the key one is currently on or when the last key is released (when pressing both keys).

The configuration of a given HS – whether set up for the left or right hand – will determine the tilting directions and which keys will constitute upper/lower.

The HS tilting configuration can be changed by tapping on the HS from any of the four sides.

2.1.1 Surface mode inputs

The keys and other inputs have assigned meanings in connection with the current item navigated to in the menu. At the same time, however, general rules, which apply wherever possible, are determined for their use.

Press upper key – select menu item

Press lower key – scroll through the menu

Press both keys – exit the menu without performing any action

Long press upper key – page up. Valid in Log book only. This has additional functions in the standard menu, indicated by a double check mark icon:

– enable or disable mixture without entering mixture edit (Setup/Mixtures/OC; Setup/Mixtures/CCR)

– Switching On/Off daylight saving (Setup/Preferences/Time&GPS/Timezone).

Long press lower key – page down

Long press both keys – return to main screen

Coded key press – switch to maintenance mode (this can be done only from the main screen)

Tilt HS away from yourself – increase the entered digit by one or check box

Tilt HS toward yourself – decrease the entered digit by one or uncheck box

Tilt HS to the left — move the cursor to the left

Tilt HS to the right — move the cursor to the right

In certain instances, such as in the menu or editing screen, helpful symbols relating to the keys are displayed. A symbol can be either next to a single key indicating the action executed if the corresponding key is pressed, or between the keys (indicating the action executed if both keys are pressed).

The **|↓|** symbol indicates the user can scroll through the menu. Scrolling in the menu is cyclical, so the cursor will return to the top of the menu list. A scroll-up function is not available due to the two-key control.

The **|↶|** symbol means going back one level without executing any action.

The **|✓|** symbol represents selecting an item or confirming an action.

2.1.2 Dive mode inputs

The input meanings in surface mode also apply to dive mode. Some exceptions are:

Long press upper key — shifts the setpoint to the next higher setpoint

Long press lower key — shifts the setpoint to the next lower setpoint

When playing decompression games, the tilting response is more sensitive. Digit entry via tilting is limited to special cases only while in dive mode.

Tapping on the display glass will switch on the display if it was switched off. It is now also possible to set numeric values using the button editor.

Setup/Preferences/Controls/Editor nav.

In the dark, shining a dive light on the display activates it in the same way as tapping on the glass. In a naturally lit environment, the display can be activated by covering and then uncovering it.

2.1.3 Language

All textual information on the CCR Liberty is in English. Controlling the apparatus requires knowledge of the English language at a level that at least allows the user to thoroughly understand this information.

2.2 Switching on the unit

Switching on the CCR Liberty's control unit requires it to be in standby mode, which is indicated on the HUD (slowly flashing blue LED) and the buddy display (slowly flashing green LED).

If the jumpers are removed (or turned so that the pins are not inserted in the connector), the rebreather's control unit cannot be turned on, except with USB power when connected to a computer via an adapter.

2.2.1 Activation

The CCR Liberty is activated by pressing both keys on either handset for three seconds.

Automatic activation occurs in the event the unit is submerged to a depth greater than 1.5 m. In such a case, the user cannot continue the dive, and must perform complete pre-dive preparation on the surface as soon as possible.

It is also possible to switch on the CCR Liberty via automatic activation in the event of damaging or losing both handsets. **Using this option is risky and should thus be considered only for a rescue attempt, for example, evacuating a diver from a siphoning cave.**

Upon activation, the rebreather switches to surface mode. If submerged to a depth greater than 1.5 m, the rebreather automatically switches to CCR mode (assuming the jumpers are connected to the batteries). **Due to a low depth sampling rate when**

the unit is switched off, the rebreather will automatically switch on after approximately one minute of being submerged at a depth greater than 1.5 meters.

WARNING: NEVER BREATHE FROM A UNIT THAT IS SWITCHED OFF! This can result in serious injury or death.

2.3 Surface mode

2.3.1 Entering surface mode

The CCR Liberty switches to surface mode when turned on by pressing the keys. In the water, surface mode can be selected in the menu if the depth is less than 1.5 m.

2.3.2 Surface mode primary screen



Date and Time

Maintain a correct local time setting; it will be used for log recording.

Stack time

The scrubber stack timer runs continuously in dive mode (except OC bailout) regardless of depth, and it can be set to run on the surface (more in "Stack timer sfc.").

If you spend a long time in dive mode while not breathing from the rebreather's loop, then increase the time for the stack time warning.

Don't forget to reset the timer when you refill the scrubber (Pre-dive → Stack time reset).

Max altitude

The maximum allowed altitude calculation is based on the ZHL decompression algorithm with an additional safety margin ($GF = 0.80$). It is a continuation of the decompression calculations and functions in the same manner as a decompression ceiling.

No fly

The calculation of the no-fly time is based on the maximum allowed altitude according to the Bühlmann decompression algorithm ZHL.

The air pressure in the cabin of a commercial aircraft is maintained at a level corresponding to air pressure at 1800–2400 m (6000–8000 feet) above sea level while cruising altitude falls in the range 11 000–12 200 m (36 000–40 000 feet).

The no-fly time calculation uses the decisive altitude of 4464 m (14 646 ft). At this altitude compartments containing the oxygen masks will be opened automatically and the oxygen masks will drop down in front of the aircraft passengers.

Battery symbol

A graphical indication shows the remaining battery capacity. The two batteries are indicated separately.

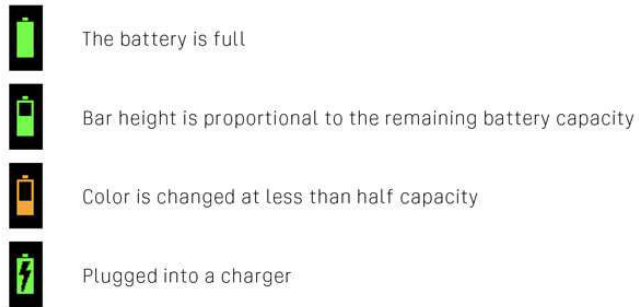

Setpoints

Descent (“-.-” if disabled), low and high setpoints are listed.

ppO₂

The measured partial pressure of oxygen is displayed.

2.3.3 Surface mode O₂ sensors screen

O ₂	62.7 mV	1.25 bar
	61.1 mV	1.21 bar
	67.2 mV	1.23 bar
	58.8 mV	1.14 bar
Diluent	12/43	pO ₂ indirect
He0	48.8%	1.19 bar
He1	48.8%	0.97 bar
pO ₂	0.72 bar	Stack 2:34

To switch between the different screens in surface mode, press the top button. Both ppO₂ and sensor voltage can be read. If a sensor is not an operational state (not connected, offline, error, excluded, disabled, uncalibrated), the appropriate tag appears instead of the ppO₂ value.

You can also find the local time, the max. difference between the sensor readings, and the stack time on the O₂ sensors screen.

If after replacing the oxygen sensor you see its voltage is negative (-10mV), then it means that the connector to the sensor is wired backwards.

2.3.4 Switching to other modes



In the menu the user can switch from surface mode to the CCR, manual CCR, bailout and standby modes.

If submerged to a depth greater than 1.5 m, the rebreather automatically switches to CCR mode.

2.3.5 ppO₂ control in surface mode

Simple ppO₂ control is started in surface mode. If the oxygen content in the loop falls below 19% (with respect to the current atmospheric pressure) the solenoid will open to add 0.5 liter of oxygen. This should ensure that the partial pressure of oxygen will climb to a value of at least 0.23bar. Oxygen is then injected in six-second intervals (three seconds after the last closing of a solenoid). This control algorithm is intended to prevent a dangerous ppO₂ decline and the subsequent loss of consciousness of the user, who may have mistakenly breathed from the circuit without activating dive mode.

ppO₂ control is subject to other conditions; the oxygen tank must be full, connected, and open. PpO₂ sensors must also be installed and calibrated. It is advised for the user to avoid excessive physical activity prior to diving on the CCR Liberty, as doing so may cause a higher consumption of oxygen.

ppO₂ control in surface mode only maintains the oxygen level closely above the hypoxia threshold; therefore, it may not be used routinely for breathing. Oxygen addition is not active when the head is connected to the charger.

2.4 Setup

The CCR Liberty is configured in surface mode. Activate the surface mode main menu with a short press of both keys and select Setup.

Some values can be set during a dive; however, this is reserved for resolving exceptional situations only.

The values set will depend primarily on the user's experience, physiology, and personal preferences. The fact that the CCR Liberty enables the user to choose his/her own values does not mean such a setting is safe or suitable for the individual and their planned dive.

If you are not sure which value to set, leave the values on the default setting.

The manufacturer does not provide a warranty for incorrectly operating the CCR Liberty if the faulty operation is the result of an improper setup.

The factory default setting values are indicated by square brackets.

2.4.1 Editor use

Most of the values are edited in a similar manner.

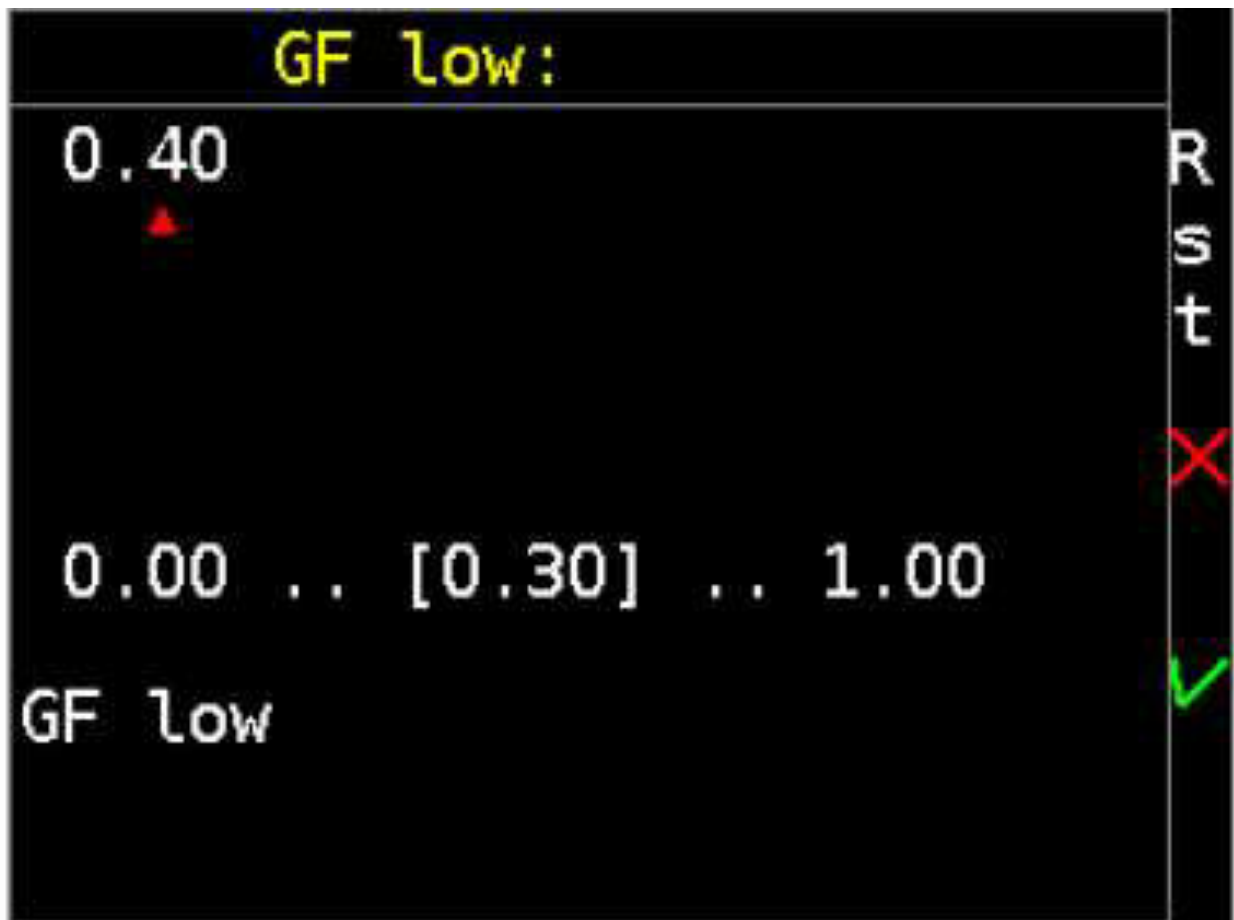

- Press lower key - moves the cursor
- Press upper key - iterates 0-9 (if we are limited by the maximum value, then 0-MAX)
- Long press lower key - moves back by one character
- Long press upper key - resets the value to default and moves the cursor to the beginning
- To save, move the cursor to the last character and press again to confirm

Alternative editing method by tilting

Tilt toward yourself— decrease the digit by one or uncheck box.

- Tilt to the left — move the cursor to the left
- Tilt to the right — move the cursor to the right
- Press upper key — discard editing (reset to previous value)
- Long press upper key — reset to default value
- Press both keys — exit without save

– Press lower key — save and exit

Permissible range is indicated by *minimum* .. [default] .. *maximum* value.

The display shows a brief description below.

2.4.2 Setpoints

Use descent SP [Off]

This enables the use of the descent setpoint.

– Use descent setpoint [On] enables Descent setpoint when starting a dive

– Use descent setpoint [On+Sfc] the same as above + when surface to 0.3m or less activates again Descent SP for repeat dives, siphon dives and others.

See also chapter 2.6.3 Descent setpoint.

Use deco SP [On/Off]

Turns on or off the decompression setpoint used especially during the ascent.

ppO₂ descent [0.4 bar]

Value of the descent setpoint (range: 0.2–1.0 bar).

See also chapter 2.6.3 Descent setpoint.

ppO₂ low [0.7 bar]

Value of the low setpoint (range: 0.4–1.3 bars).

See also chapter 2.6.3 Setpoint.

ppO₂ high [1.3 bar]

Value of the high setpoint (range: 0.7–1.6 bars).

See also chapter 2.6.3 Setpoint.

FO₂ limit [90%]

The setpoint is limited to the percentage of ambient pressure (range: 60–96%).

Setting a percentage that is too low reduces the effectiveness of decompression in shallow depths. Setting a percentage that is too high in shallow depths increases the intake of oxygen, which makes it necessary to discharge the contents of the breathing loop and makes balancing more difficult.

See also section 2.6.3 Setpoint limitation.

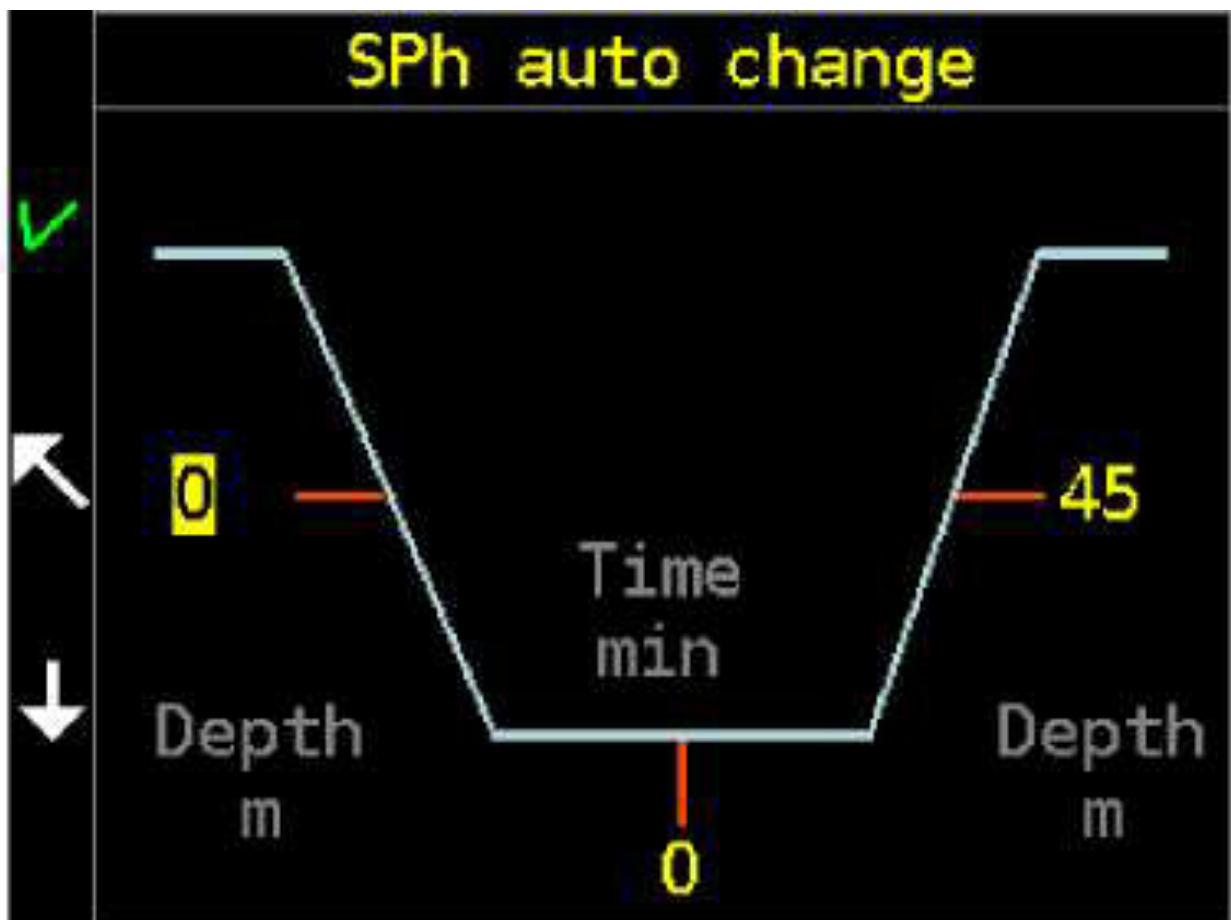

SPh auto

Automatic switching to high setpoint if values greater than 0 are entered into the chart, the unit will automatically switch to high setpoint according to specified parameters when underwater. This can occur due to exceeding a certain depth during descent, bottom time, or exceeding a certain depth during ascent.

The values are entered into the chart of the dive profile schematic. Navigate the chart

with the bottom button, select the item with the top button, tilt to edit.

For re-dive activation, the diver must first ascend to 0.3m or shallower, and on subsequent dives (without exiting dive mode) AutoSP-High or AutoSP-Descent is reset at 1.5m.

SPdeco auto

Setting of automatic decompression setpoint switch.

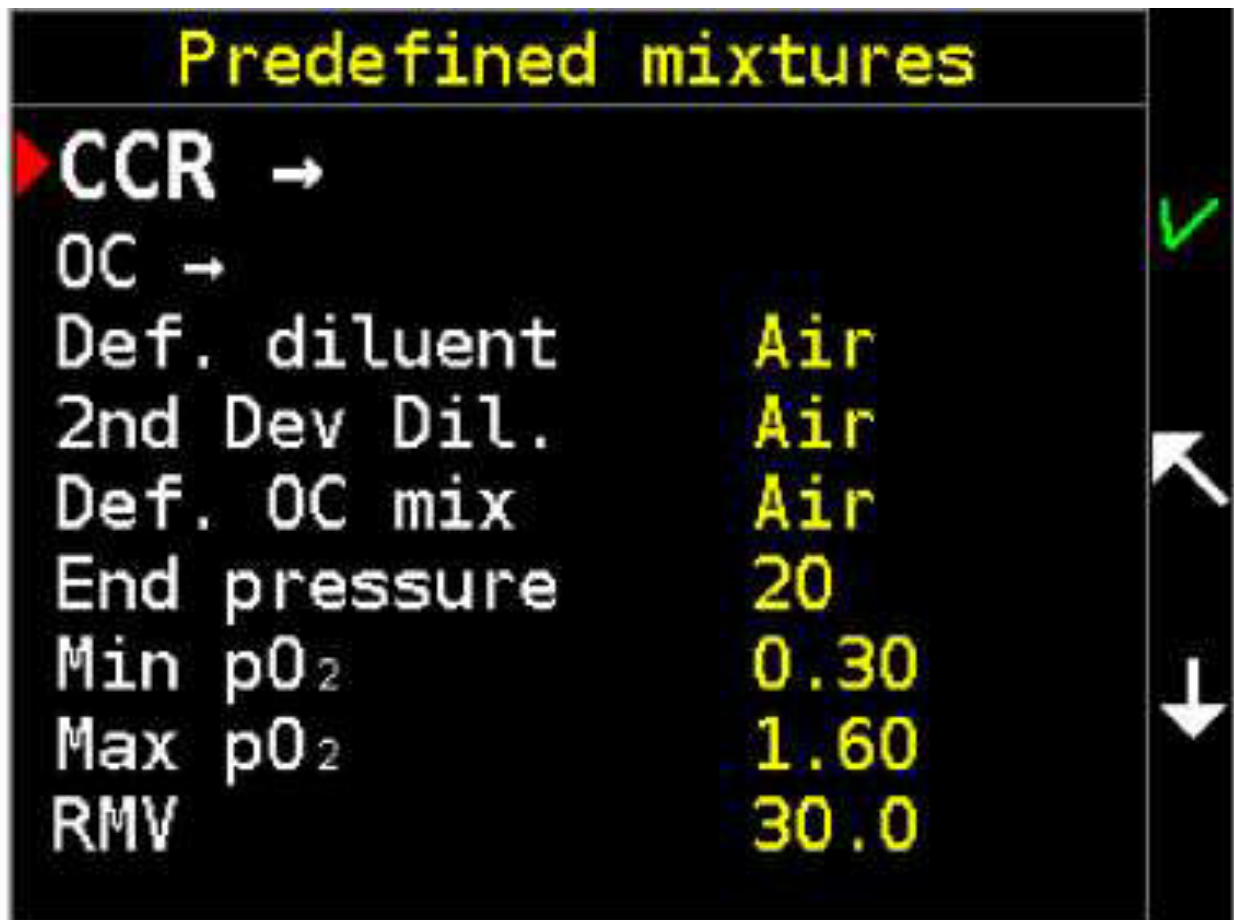

2.4.3 Mixtures

CCR

Eight different diluent mixtures with variable fractions of oxygen, nitrogen and helium can be preset.

Select the mixture to edit with the upper key short press, and use tilting for changing the values or cursor position.



Each mixture can be enabled (marked checkbox) or disabled (clear checkbox). This can be done in the editing screen or via a shortcut – long press of the upper key in the list of mixtures.

Next to every gas mix MOD and END is displayed. MOD is calculated in a way in which the diluent will always be able to dilute the mixture in the loop. It is calculated from a partial pressure 0.2 bar lower than the high setpoint.

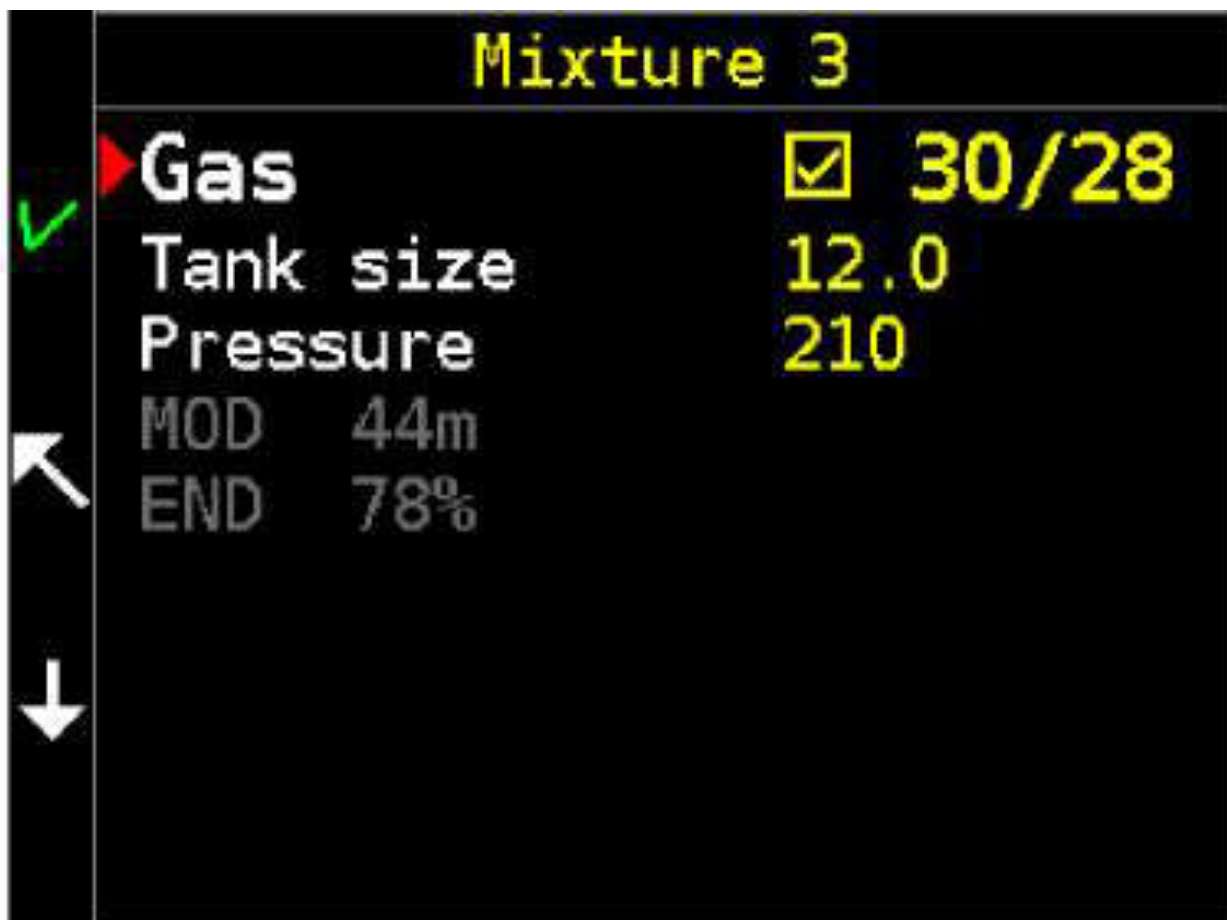

The mixture you use as a diluent must be one of the selected mixtures. Setting an incorrect diluent composition will lead to an incorrect calculation of the decompression procedure and can lead to an inaccurate proportion of oxygen in the mixture if the rebreather switches to indirect measuring using the He sensors.

See also section 3.2.5 Diluent.

OC

Eight different OC bailout mixtures with various fractions of oxygen, nitrogen, and helium can be preset.

Each mixture can be enabled (marked checkbox) or disabled (clear checkbox). Only enabled mixtures can be selected.

Next to every gas mix a pressure (bar or PSI) and cylinder volume (litres or cubic feet) is displayed. During mixture editing, we set individual items separately. MOD (maximal operational depth) is displayed in a grey font, taking a maximum ppO_2 of 1.6 bar and END (equivalent narcotic depth) into consideration. END is usually

expressed as the depth at which diving with air would have the same narcotic effects as the inert gases used in the current mixture. This theoretical depth is the equivalent of a specific target depth. In this case, however, the target depth is not known, therefore, the END is expressed as the % narcotic effect of the mixture on the air.

Mixtures that you have prepared for bailout (or staging) must be entered and enabled.

Unused gas mixes must be disabled. Otherwise, the gas management calculations or BO RMT will be skewed.

In an emergency, a mixture can be enabled or even newly defined during a dive. However, this should be reserved for emergency situations only.

Def. diluent

An alternative default diluent can only be selected from mixtures that are enabled.

2ndDef. Dil

If a backup rebreather is used, it defines the composition of the diluent in the backup for relevant decompression calculations.

Def. OC mix

An alternative default OC bailout mixture can be selected only from mixtures that are enabled.

End pressure

End-of-tank pressure for planning gas management in the scheduler and BO RMT during the dive.

Min PO₂

Specifies the usability of OC mixtures with respect to the minimum ppO₂.

Max PO₂

Specifies the usability of OC mixtures with respect to maximum ppO_2 .

RMV

Respiration minute volume is used to calculate gas management in scheduler and BO RMT during dive. We recommend setting a sufficient margin to deal with an emergency situation. RMV during a CO_2 hit can significantly exceed 50 l / min.

2.4.4 Decompression

GF low [0.30]

Gradient factor at the start of decompression (range: 0.05—1.00)

GF low determines an additional increase in safety at the decompression ceiling depth at the start of decompression. Setting a value of 1.00 corresponds to the Bühlmann decompression algorithm without an additional increase in safety using the gradient factor method.

Setting low values leads to deeper and longer stops at the start of decompression.

GF high [0.80]

Gradient factor at the end of decompression (range: 0.10—1.00)

GF high determines an additional increase in safety when ascending to the surface. Setting a value of 1.00 corresponds to the Bühlmann decompression algorithm without an additional increase in safety using the gradient factor method.

Setting low values leads to longer shallow decompression stops.

Bailout GF low [0.80]

Gradient factor for bailout at the start of decompression (range: 0.05—1.00)

As a general rule for bailout GF low, a higher GF value (a lower additional increase in safety) is set.

Bailout GF high [0.95]

Gradient factor for bailout at the end of decompression (range: 0.10—1.00)

As a general rule for bailout GF high, a higher GF value (a lower additional increase in safety) is set.

Deco model

You can choose between the decompression models ZH-L16B and ZH-L16C.

Decompression model C is slightly more conservative than model B.

Rate & zone

This item allows you to set the descent and ascent speeds. The input is done in the schematic dive profile chart. Navigate the chart with the bottom button, select the item with the top button, tilt to edit. The "descent rate" is rate used exclusively in planner for descend. The following "warn under" depth is the first depth from which you may get the descend rate alarm, if you exceed the set "max rate". This setting is intended to limit the possible HPNS caused by fast descend in the deep part of the dive.

The ascent rates are divided into three zones: the maximum depth of the first limit; from the first limit to a second limit; and finally from the second limit to the surface. These limits can be defined in the graph on the right. The rates in the individual zones are part of the graph on the left output side.

Planner setup

The planner is used to help setup decompression and gas management plans. For a detailed description, see Planner settings – section 3.1.1

Reset deco data

This resets the saturation of inert gases and the calculation of oxygen toxicity to a state that corresponds to a very long period after the previous dive.

A diver that uses the CCR Liberty after resetting the decompression data should not dive for 48 hours prior to submersion with the reset apparatus. Do not dive for 24 hours with a reset apparatus after significantly increasing altitude above sea level.

2.4.5 Alarms

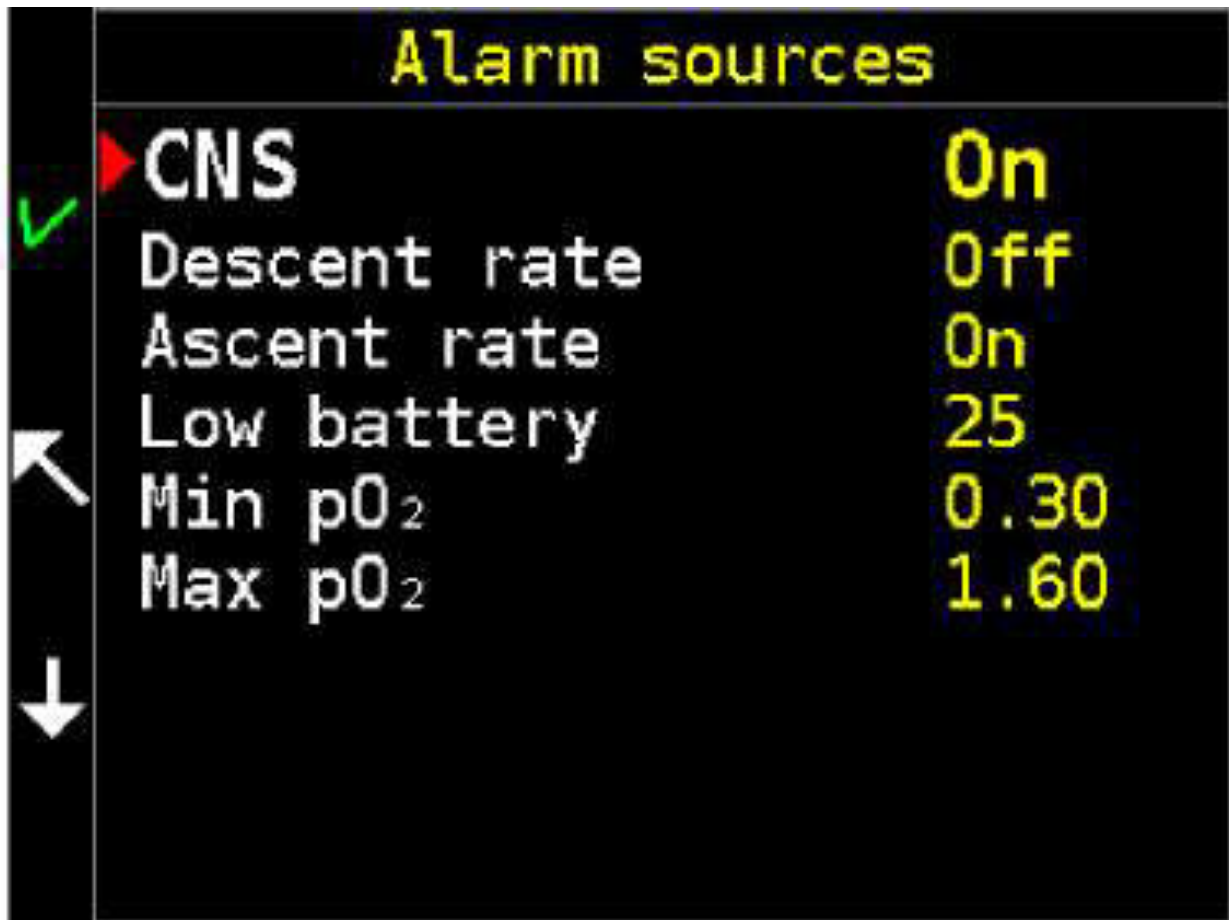

Alarm sources

CNS [On]

Oxygen toxicity limit has been reached.

Descent rate [Off]

Descent rate has exceeded the set limit.

Ascent rate [On]

Ascent rate has exceeded the set limit; the system tolerates very short, fast movements.

Low battery [25%]

Battery power has dropped below the set limit (range: 0–40%). Setting 0 means deactivation of this alarm.

Min PO₂

Specifies the lower limit for ppO₂ alarm in CCR dive mode.

Max PO₂

Specifies the upper limit for ppO₂ alarm in CCR dive mode.

Air inegr.

Enables or disables low cylinder pressure alarms or loss of communication with the transmitter.

Notifications

Notifications		
✓	▶ No deco end	On
	Gas sw. reminder	Off
	Gas switch done	On
←	Depth & Time →	
	Stack time	240
↓	Stack timer sfc.	Off

No deco end [On]

End of the dive in zero time (Bühlmann decompression model terminology), i.e. notification that it will be necessary to reduce the ascent rate and/or perform decompression stops.

Gas switch reminder [Off]

The alarm advises the user to switch to a different mix. This is used only in bailout OC mode.

Gas switch done [On]

Notifies that a change in mixture (in bailout OC mode) or diluent has been executed.

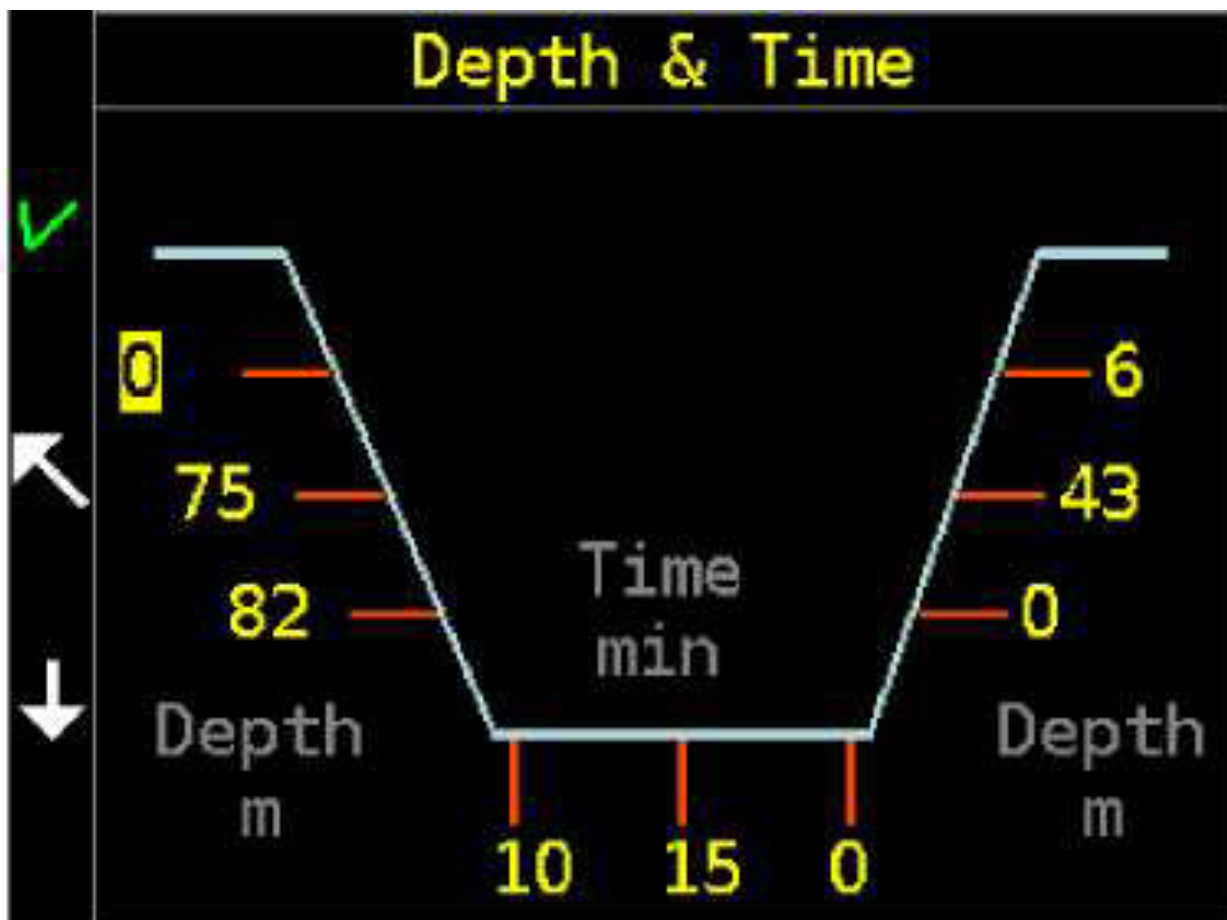

Depth & Time

Depth and time notifications are set through a dive schematic graph. Navigate the graph using the bottom button, select with the top button, and set the values by tilting the computer.

Notification that the set **depth during the descent** has been reached. It is possible to set three separate depths within the range of 0 – 300 m. 0 means deactivation of the notification.

Notification that the **dive time** has been reached. It is possible to set three separate times within the range of 0 – 999 min. 0 means deactivation of the notification.

Notification that the set depth **during the ascent** has been reached. It is possible to set three separate depths within the range of 0 – 300 m. 0 means deactivation of the notification.

Stack time [150 min]

Notification that the cumulative time in any close circuit dive mode has been reached (range: 0 – 360min). 0 means deactivation of the notification.

To reset a timer go to the Pre dive menu.

Stack timer sfc.

This feature can be set to not count stack time when in surface mode.

On – counted on the surface

Off – not counted on the surface

BO RMT expiration

Enables or disables notification for end of bottom time with respect to bailout gas supply for emergency surfacing.

2.4.6 Preferences

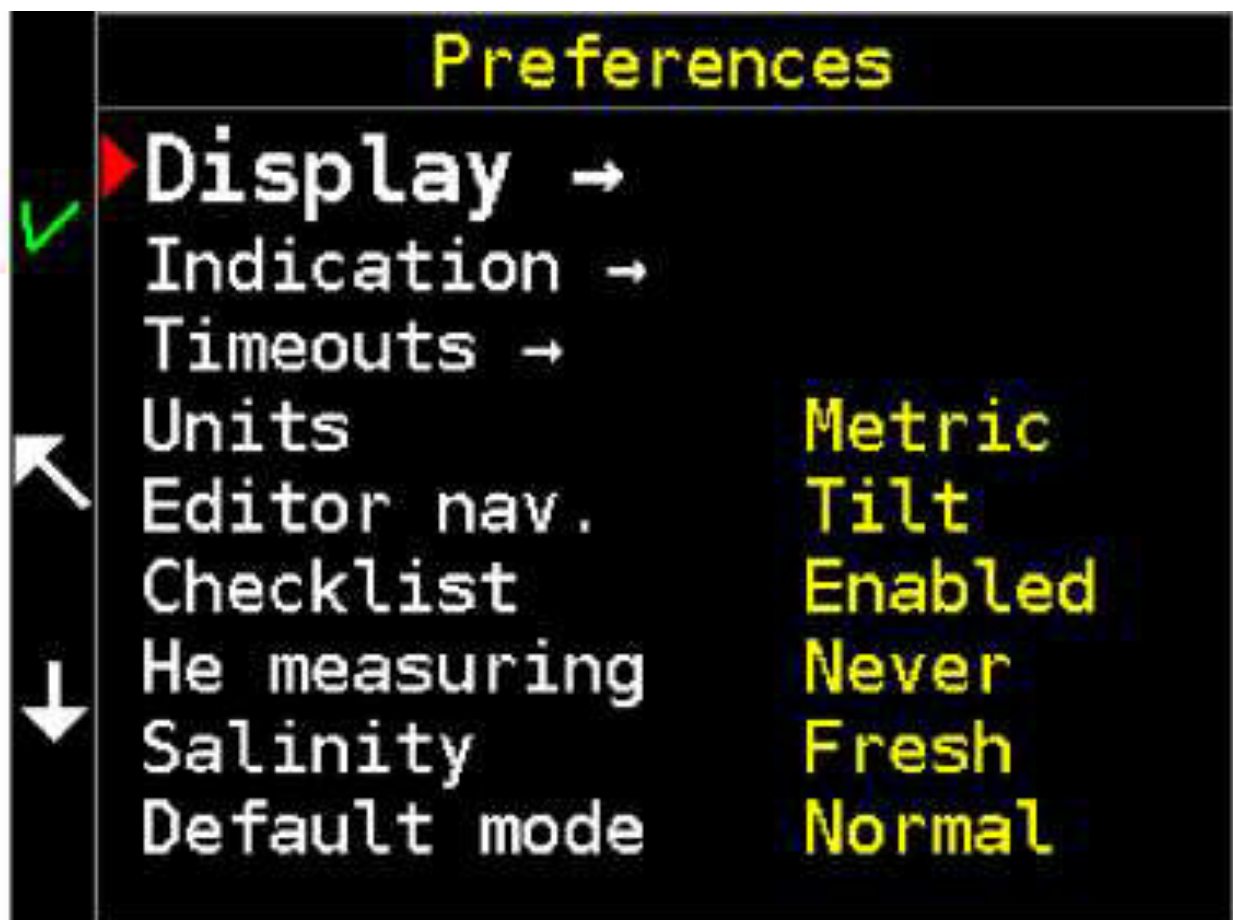

Display

Orientation

Setting for left/right hand.

Brightness

Adjusts the brightness of the handset display. Note: Display brightness significantly affects battery life.



Screensaver

The display becomes inactive after a set period of timer (range: 0—120 s). 0 means that the display will be constantly active.

Screens

Any of the five following screens can be enabled or disabled. This can be done during a dive.

Detailed — the primary screen displays all necessary information

Synoptic — the depth value is easy to read; it is accompanied by other important information

Big — the most important information written in large characters

Graph — Dive profile screen

O₂ sensors — detailed state of the sensors

TTS — Time to surface screen with unique BO RMT value and future TTS

Tank press. [Num.] / [Graph] / [All]

Determines how cylinder pressures are displayed on the detail screen. Numerically instead of time and CNS, or graphically instead of solenoid opening symbols.

Indication

Auxiliary displays

This refers to setting the position of HUD and buddy display. The default position for the HUD is on the right side and on the left side for the BD.

Color blind mode

If you cannot distinguish blue and green LED lights on the HUD, switch the color blind mode on. See section 1.10.3 Color Blind mode.

Timeouts

Key delay [0]

Minimum key press duration (range: 1 — 5, in 100 ms).

Auto switch off [45]

This represents the time period after which the CCR Liberty switches from surface mode to standby mode (range: 0 – 999 min.). 0 deactivates automatic switching to standby mode. If no handset is connected, a switch-off will occur after 150 minutes regardless of the setting.

Time & GPS

Set time

Sets the time manually only when GPS synchronisation is not used

Timezone + DST [']

Time zone setting – necessary for correct synchronization with GPS long hold summer/winter time

Date format [ISO / EU / US]

ISO "YYYY-MM-DD"

EU "DD.MM.YYYY"

US "MM/DD/YYYY"

GPS Sync Time [On / Off]

Automatic time synchronisation according to GPS

GPS Log2SD [Off/DiveDay/Always]

Logging of the traveled route to SD card (downloadable via USB cable) logs every 20s position + HDOP (accuracy) *.GPX – xml format for google maps.

DiveDay - logs approx. 30 minutes before dive and 30 minutes after surfacing, marks dive and surfacing location.

Always – always logs if it has a signal ... not recommended because it will generate enough files on the SD card.

GPS format [DDDDD...]

Formát nastavení a zobrazení souřadnic

"DD.DDDDD"

"DDMM.MMM"

"DDMMSS.S"

Units & Misc

Units [Metric]

Metric and imperial units can be set for the entire apparatus. All physical calculations are internally executed using the metric system; results are converted for display only.

Salinity

This feature assesses the appropriate water salinity (Fresh/Sea). It has a direct influence to depth measurement.

Checklist [enabled]

When entering CCR mode from the surface mode menu, a checklist is displayed. This can be disabled.

BoCCR setting[Off/On]

In other menus it enables setting of relevant items for CCR bailout (Mixtures, Default mode, Bailout stby (CCR) mode).

Default mode [Main /Bailout]

Default mode of the unit when switched on by diving / jumping into the water.

Help [On/Off]

Help for each menu item, displayed after 10s on one line.

Editor navig. [Tilt]

The numbers in the editor can be increased or decreased by tilt or by tap. The tapping option may require some practice. Do not change the tilt setting unless you have a strong reason for preferring the tapping.

He measuring [TMX only]

TMX only – He sensors are used only in the case that the selected diluent contains > 20% helium. **Never** – He sensors are permanently deactivate.

2.4.7 Calibration

Calibrate He-Air

The He sensors are calibrated with air. The sensor is stable for a long period of time; therefore, perform a calibration only after replacing the sensor or if there are doubts about its accuracy. Sensors must be free of any traces of helium.

O₂ purity [99.5%].

The oxygen concentration in the calibration gas can be set. If possible, use oxygen with a purity of at least 99.5% for calibration.

Do not use air for calibration. The partial pressure of oxygen in air at atmospheric pressure differs significantly from the partial pressures determined by the setpoints. At the end of its service life, an oxygen sensor can successfully undergo calibration to 21% (air) but will no longer be capable of measuring a ppO₂ of 1 bar or higher.

See also section 3.2.8 Calibration of oxygen sensors and 3.2.5 Oxygen.

Calibrate pressure

Recomm. days [3 days]

Recalibration of the oxygen sensors will be recommended after a set number of days (range: 0–30).

Horizontal calibration

The accelerometers are used for control by tilting and tapping. They have to be calibrated. Place the handset on a level surface (e.g. a table) before starting a calibration.

2.4.8 Faulty sensors

Oxygen sensors

This is the oxygen sensor status overview. Based on the results, the user may have to exclude individual oxygen sensors for ppO_2 calculation.

Normal – no sensor malfunction detected; the sensor is used as a data source.

Uncalibrated – sensor has not been calibrated.

Excluded – sensor excluded automatically by the algorithm. The algorithm can return the sensor to Normal status if it determines that the reason for exclusion has no longer exists.

Disabled – sensor excluded manually.

Error – sensor not present, or bad contact.

Offline – sensor not available (digital communication at the module level is not functioning).

Helium sensors

It is possible to include and exclude helium sensors.

Normal – no sensor malfunction detected; the sensor is used as a data source.

Uncalibrated – sensor has not been calibrated.

Disabled – sensor excluded manually.

Error – sensor not present, or bad contact.

Offline – sensor not available (digital communication at the module level is not functioning).

Pressure sensors

This is the pressure sensor status overview. Based on the results, the user may have to manually exclude individual sensors. Do not start a dive with more than one malfunctioning pressure sensor.

Normal – no sensor malfunction detected; the sensor is used as a data source.

Disabled – sensor excluded manually.

Error – sensor not present, or bad contact.

Offline – sensor not available (digital communication at the module level is not functioning).

See also section 1.9.5 Pressure and depth measurement.

Other devices

You can switch off a solenoid that is not functioning properly. If so, the other solenoid overtakes completely, and its frequency is corrected from 12 seconds to 6.

pO₂ source

Switching the data source for the control of oxygen partial-pressure in the loop

O₂ – Oxygen sensors are used for measuring and controlling the oxygen

He – He sensors are used to indirectly measure and control the oxygen

pO₂ source is only allowed if helium measurement is enabled

2.5 Dive mode



2.5.1 Detailed screen

The primary screen displays all necessary information during a dive. Most information is provided by clear values and unambiguous symbols.

Dive time The timer starts after submersion (depth > 1.5 m) and halts after surfacing (depth < 0.5 m). In case

of a stay on the surface (or at a very shallow depth) followed by a second submersion (during a time set in the dive termination timeout) the dive time indicated will be the time from the first submersion including the surface time.

Depth

The depth can be read in the units selected in the setup (m or ft). Depth is calculated from measured hydrostatic pressure. Fresh water (default) or seawater density can be set for the depth calculation (units and salinity are set in Setup → Preferences).

Setting fresh/sea water does not affect decompression calculations. Decompression is based on ambient pressure and is independent of the displayed depth.

No deco

You can stay for the indicated time at the current depth, breathing the current mixture (current He content and current SP), to avoid a decompression obligation. It is, however, presumed that the diver will follow the recommended ascent rate.

During the dive, there is a situation where the No Deco indicator already shows a zero value, but the decompression ceiling value is still not displayed. Such a situation can last for tens of seconds. The scenario is due to the fact that the No deco time has ended and the decompression ceiling is below the surface level, but its value is so low that there is no need for staged decompression as a free ascent is advised.

Ceiling

The depth of the decompression ceiling decreases continuously up to the surface. The stops displayed are never random. Always stay below the depth of the ceiling, even if the ceiling depth is very shallow.

The ceiling indicator in the Liberty replaces the indicator of decompression stops. The diver selects the depth at which they do the decompression stop or steadily ascends in accordance to the decompression ceiling. This approach may be more effective in terms of decompression time. Time reference is TTS (Time To Surface). Do not follow the decompression ceiling at low depths if conditions do not permit it. Waves, currents, positive lift of gear at a shallow depth, no visual reference, and other factors can cause uncontrolled ascent above the ceiling or completely hinder decompression at this level.

Ascending above the ceiling generates a warning. A further violation of more than 1 m (3 ft), leads to an additional alarm. Both alarms are logged. The decompression

calculation will continue without a penalization. The diver is responsible to decide how to minimize the probability of severe consequences.

Decompression is no longer required when the ceiling value disappears. In that case, it is possible to surface.

TTS

The time to surface (TTS) includes the complete decompression profile. The rounding of TTS is influenced by the settings in Menu / Setup / Decompression / Planner setup / Rounding. The rounding can be set to 60 s, 30 s, 1 s.

Battery symbols

Combined graphic symbol

A combined graphic symbol on the detailed screen is intended for rapid awareness. It tells the diver what must be done. The color of the warning symbols changes from yellow to red according to the degree of severity.

Battery symbols



The battery is full



Bar height is proportional to the remaining battery capacity



Color is changed at less than half capacity

Combined graphic symbol



Permitted to ascend to the surface.



Permitted to ascend to the depth of the decompression stop or decompression ceiling.



The depth of the decompression ceiling or decompression stop has been reached; do not change depth.



The depth of the safety stop has been reached; do not change depth.



The ascent rate has been exceeded; slow your ascent.



The current depth is less than the depth of the decompression ceiling; descend.

t (Temperature)

Water temperature is measured inside the HS housing. After a water temperature change wait about 1-2 minutes until the temperature reading is stable. The air temperature is affected by many factors and is only an approximate reading. If you see a yellow exclamation mark next to the temperature value, it means that the other handset is not communicating and the temperature is calculated based on only one sensor. In case you are using only one handset, you can switch the unit to the sidemount settings: Setup / Preferences / Controls & Build / Mount -> **Side**.

CNS

The so called "oxygen clock" is a percentage of consumption of CNS toxicity limit. Calculation is based on NOAA oxygen exposure limits.

See also section 3.4.1 Breathing high oxygen content gases.

Diluent

The currently used diluent is displayed.

Solenoid symbols

In the lower left and right corners, there are symbols indicating the state of the solenoids according to data from the control units.

X – solenoid is closed

= – solenoid is opened

SP

The setpoint is a required ppO_2 value. The setpoint values are usually displayed in white. The setpoint value will be displayed in yellow when the value is not physically reachable (ex. Setpoint of 1.4 in 2 meters). The evaluation of the ability to reach the setpoint is influenced by the maximum FO_2 . For instance, a setpoint of 1.3 in 3 meters can be reached, but only if there is 100% of oxygen in the loop, but if the FO_2 is set to

80% then the setpoint will be displayed in yellow, and the solenoid will not add oxygen for as long as the value of ppO_2 does not drop below 1.04bar [1.3×0.8]. The setpoint value will be displayed in red only when the setpoint is changed.

For information on adjusting the setpoint, see section 2.6.3 Setpoints.

O₂ sensors

The ppO_2 measured by individual O₂ sensors is displayed.

ppO₂

The ppO_2 can be measured directly (using O₂ sensors) or indirectly (using He fraction sensors). **It shows the average value.**

See section 1.9.2 Direct measurement of ppO_2 and 1.9.3 Measurement of He content.

Exclamation mark

If a yellow exclamation mark is displayed next to a value, it means that one or more sensors were excluded. This applies to the measurement of ppO_2 , temperature, pressure and helium.



2.5.2 Synoptic screen

The depth value is easy to read. It is accompanied by other important information.

The value meanings are indicated on the screen.



2.5.3 Big Screen

The most important information is written in big characters.

This screen is useful when visibility is very bad. Many divers can read the numbers even without a mask.

2.5.4 Dive profile screen

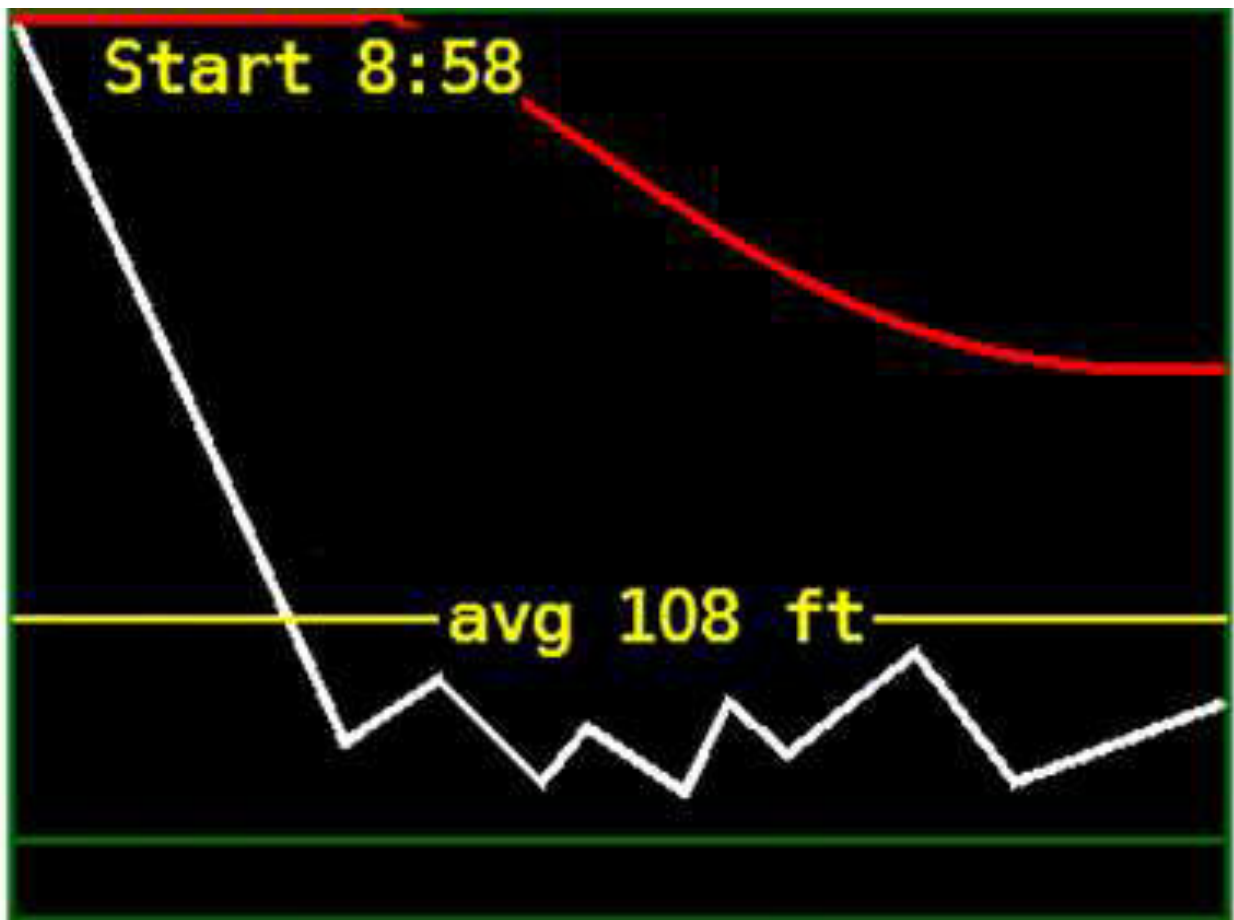

Start

The time of submersion is useful for checking compliance with the schedule.

Avg

The average depth is indicated with the yellow horizontal line and with a number displayed in yellow.

Current depth

See lower left corner.

Dive time

Runtime of current dive is placed in lower right corner.

Max

This is the maximum depth reached during the dive. The field with this value is placed in the middle of the bottom line.

O_2	62.7 mV	1.25 bar
	61.1 mV	1.21 bar
	67.2 mV	1.23 bar
	58.8 mV	1.14 bar
Diluent	12/43	pO_2 indirect
He0	48.8%	1.19 bar
He1	48.8%	0.97 bar
pO_2	0.72 bar	Stack 2:34

2.5.5 Sensors screen

This screen displays the value potentials of the sensors and their calibrated ppO_2 values.

Diluent

The composition of the current diluent (O_2/He)

He0 / He1

Helium content in the loop as detected by the individual helium sensors. Under ideal conditions the measured value will correspond to the fraction of helium in the diluent.

pO_2

Partial pressure of oxygen in diluent at current depth.

pO_2 indirect

Indirectly measured ppO_2 using helium sensors. The cell is shaded blue. When using indirect measurement of ppO_2 via the helium sensors, the cell will also be shaded blue.

Stack

Scrubber stack time

2.5.6 TTS Screen

BO RMT 21	BO TTS 14:12	
Depth m 51.4	TTS 11:10	
Ceiling 17.6	pO_2 1.21	
TTS (+2) 14	TTS (+5) 19	TTS (+10) 26

This screen contains useful and unique timeout information.

BO RMT

Bailout remaining time is the time that determines the maximum stay length at the current depth so that the bailout gas supply is sufficient for the entire ascent, including decompression.

The algorithm counts all the set gases and their amount together with the specified minute consumption (RMV). In order for the calculation to be correct, it is always necessary to accurately enter the volume, pressure, and composition of the gas and to have only those gases actually used in the gas list. BO RMT is calculated based on the Bailout GF setting. If bailout rebreather is used as bailout source and Bo CCR mode is enabled in Setup -> Miscellaneous, then BO RMT is calculated based on:

- battery life
- scrubber depletion (Stack time)
- AI i oxygen pressure and the specified bottle size, it calculates a metabolic consumption of 1.6 l/min

The value is displayed in Bo CCR mode on the "Sensors screen" instead of the helium sensors. When the BORMT expires BoCCR will trigger an alarm.

BO TTS

The time required to surface in the case of OC bail out ascent. The ascent time is calculated according to the Bailout GF setting

TTS (+2) (+5) (+10)

The values of these three items represent future TTS (i.e. the length of ascent if the diver stays at the current depth for the next 2, 5, or 10 minutes). In the saturation phase of the dive, the values increase gradually; in the desaturation phase; it is the opposite.

2.6 CCR mode

This is the primary dive mode with the CCR Liberty.

2.6.1 Entering CCR mode

The standard method of switching to CCR mode is by selecting it in the menu from surface mode. If submersion to a depth greater than 1.5 m occurs in surface mode or

standby mode, the rebreather will automatically switch to CCR mode. **Do not intentionally use this switching method; it is intended only for emergency situations.**



The process of switching to dive mode has the following course. By choosing dive mode, oxygen injection is started immediately based on the current partial pressure of oxygen and setpoint settings. At the same time, oxygen sensors are automatically verified, and their calibration is checked. If the calibration is older than the established number of calibration days, or the sensor voltages differ by more than 10%, warnings and recommendations for new calibration of oxygen sensors are shown.



The next step is a pre-dive checklist. The diver should follow this list step by step and personally check all the items marked on it. Move to the next screen using the bottom button.

After checking all the checklist items, the prebreathe screen appears. Prepare the device for prebreathing. Press the upper button to count down the pre-breathing time. The rules and procedure for prebreathing are described in section 3.2.12.



In the lower right corner, the average ppO_2 is displayed. All sensors and other values can be monitored on the second handset, where all dive mode screens are accessible. If pre-breathing is interrupted, the countdown can be reset with the lower key.

The end of pre-breathing is reported by vibration and "FINISHED". If the diver does not continue by himself, after a few seconds, the basic Dive mode screen will automatically appear



2.6.2 Switching to other modes

It is possible to switch from CCR mode to the manual CCR and bailout OC modes in the menu. If the current depth is less than 1.5 m, it is possible to switch to surface mode and standby mode.

2.6.3 ppO₂ regulation

The basic function of the CCR Liberty is to maintain correct partial pressure of oxygen.

A predictive algorithm of ppO₂ control is used. Measured ppO₂ is adjusted according to the mathematical model of the breathing loop. The calculation of O₂ delivery and possible subsequent opening of the solenoid is performed at six-second intervals. Oxygen is added alternately using the solenoids corresponding to both control units.

In the event that it is not possible to determine the actual depth (due to a malfunction or manual exclusion of all pressure sensors), regulation of oxygen

delivery switches to a simple algorithm.

Setpoint

The setpoint is a required ppO_2 value; for information on adjusting the setpoint, see section 2.4.2 Setpoints. Two special values, “low setpoint” and “high setpoint” are fixed. These can be selected simply by a long press of the upper key (for the high setpoint) or lower key (for the low setpoint).

In the default setting, the low setpoint has the value of 0.7 bar (70 kPa). It is possible to reset it within the range of 0.4 to 1.3 bar.

In the standard setting, the high setpoint has the value of 1.3 bar (130 kPa). It is possible to reset it within the range of 0.7 to 1.6 bar.

Upon starting the CCR dive mode, the low setpoint is activated by default.

Descent setpoint

The descent setpoint is designed for situations when the diver needs to rapidly descend to a given depth, for example, when diving in a current. The utilized algorithm uses the natural rise of ppO_2 during descent. It is necessary to descend rapidly; the natural rise of ppO_2 has to be faster than the oxygen consumption.

Use of the descent setpoint must be enabled in the configuration.

If it is enabled, the descent setpoint is automatically activated when switching from surface mode to CCR mode. It cannot be activated in another way. The descent setpoint has a variable value. The initial set value gives the ppO_2 on the surface. At depth, the current setpoint increases linearly by 0.2 bar (20 kPa) for every 10 m of depth (i.e. it increases by the same absolute values as when diving with an open circuit with air, only with a different initial value).

The descent setpoint is automatically switched to the low setpoint upon reaching that value or upon completing or significantly slowing down the descent, but no later than after ten minutes.

When using the descent setpoint, the user must continuously check whether he/she has reached or exceeded the maximum physiologically permissible ppO_2 limit and adjust the rate of descent accordingly, or take other measures.

Descent setpoint can be re-enabled by key shortcut or from the Setpoint menu (if we are at an applicable depth).

If On+Sfc is set in Setup / Setpoints / then the descent setpoint at the surface will never timeout.

WARNING: if the initial Descent SP value is lower than the set threshold for the Low ppO_2 alarm, then while the Descent SP is active it will only alarm if it reaches 0.05bar less than the current Descent SP value - this is especially true at depths shallower than 6m when the Descent SP is set to 0.2bar (at the surface) and the default Low ppO_2 alarm is 0.3bar.

Setpoint limitation

Besides the set value, the setpoint limit is defined by the ambient pressure. For example, at a depth of 3 m, where the hydrostatic pressure is 1.3 bars, ppO_2 can reach a maximum of 1.3 bar when using pure oxygen.

Since obtaining a precise 100% of oxygen in the loop is not always practical, the setpoint is set at 90% of the ambient pressure by default. This value can be reset within the range from 60% to 96%.

Emergency ppO_2 control

If all chemical sensors are not valid (error, disabled etc.), the depth is < 6m/20ft, and the ppO_2 source is from O_2 sensors, an emergency O_2 injection + alarm is done every 6s.

The unit assumes that in a depth lower than six meters the risk of hypoxia is greater than the risk of hyperoxia, and prevents the fatal consequences of dysfunctional or

disabled sensors. In this case, the diver must not continue his/her descent until the ppO_2 stabilizes and the diver is sure of the breathing mixture.

Emergency ppO_2 control by indirect measuring with He sensors

If all chemical sensors fail in dive mode, an alarm “ pO_2 measuring lost” is brought up.

Indirect measurement of ppO_2 using helium sensors can only be activated manually, provided that the helium measurement setting is switched on (TMX only) and the helium fraction in the diluent is greater than 20%. When using indirect oxygen measurement with helium sensors, always be sure that helium sensors are calibrated and functional.

For indirect oxygen measurements, all fields displayed with ppO_2 are blue.

2.6.4 Decompression

The decompression algorithm takes measured ppO_2 values and inert gases according to the set diluent composition into account.

During a dive, the safety level can be set in the menu by switching the set of standard and bailout gradient factors (GFs) without affecting the mode in which the CCR Liberty is operating.

2.6.5 Specific handset control

Long press upper key — next higher setpoint

Long press lower key — next lower setpoint

If Descent SP and Deco SP are enabled in the settings, switching with key shortcuts also takes place between them.

2.7 Manual CCR mode

This mode serves primarily for training



2.7.1 Entering manual CCR mode

It is possible to switch to manual CCR mode from the menu in CCR mode, bailout OC mode, or surface mode.

2.7.2 Switching to other modes

In the menu, it is possible to switch from manual CCR mode to CCR mode and bailout OC mode. If the current depth is less than 1.5 m, it is possible to switch to surface mode and standby mode.

2.7.3 ppO₂ regulation

Manual CCR mode is based upon CCR mode. However, automatic replenishment of oxygen is not available, and ppO₂ regulation is performed only manually. The display

of ppO_2 , decompression calculations, and other data is operational.

It is assumed that the user adds oxygen manually using the manual bypass valve or by manipulating the oxygen-tank valve if any solenoid is locked in the open state.

If the ppO_2 falls below 0.3 bar, then oxygen will be added to the breathing loop automatically for safety reasons. This is possible only if the solenoids are operational and an oxygen supply is available.

When manually adding oxygen to the breathing loop, anticipate a delay between adding oxygen and the change in measured values. This delay is due to the fact that oxygen is added to the exhalation bag and the mixture must pass through the scrubber before it reaches the sensors.

2.7.4 Decompression

The decompression algorithm takes measured ppO_2 values and inert gases according to the set diluent composition into account.

2.8 Bailout OC mode

This mode serves primarily for resolving emergency situations.

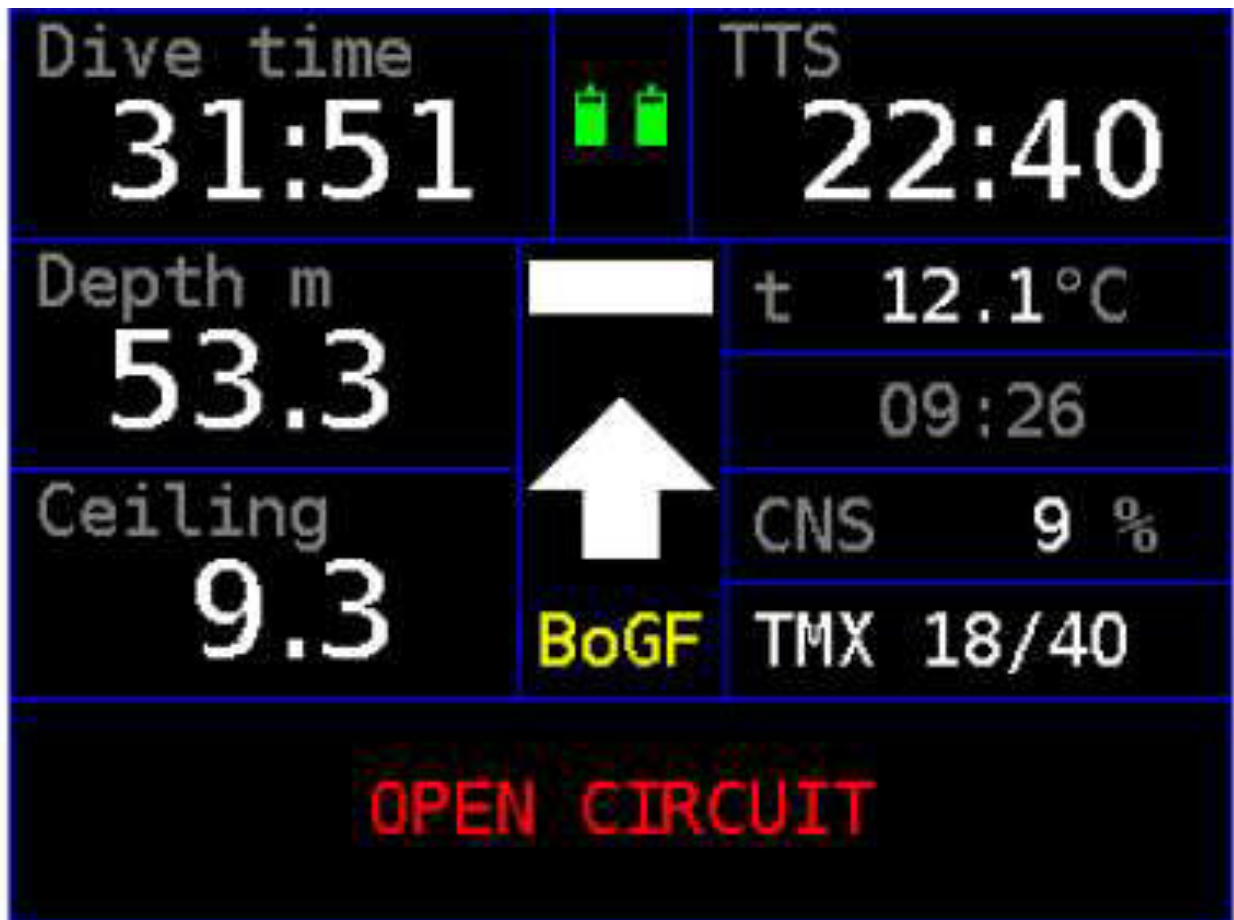

2.8.1 Entering bailout OC mode

Switching to bailout OC mode is achievable from the menu in CCR mode, manual CCR mode, or surface mode.

2.8.2 Switching to other modes

In the menu, it is possible to switch from bailout OC mode to CCR mode and manual CCR mode. If the current depth is less than 1.5 m, it is possible to switch to surface mode and standby mode.

2.8.3 Mixture

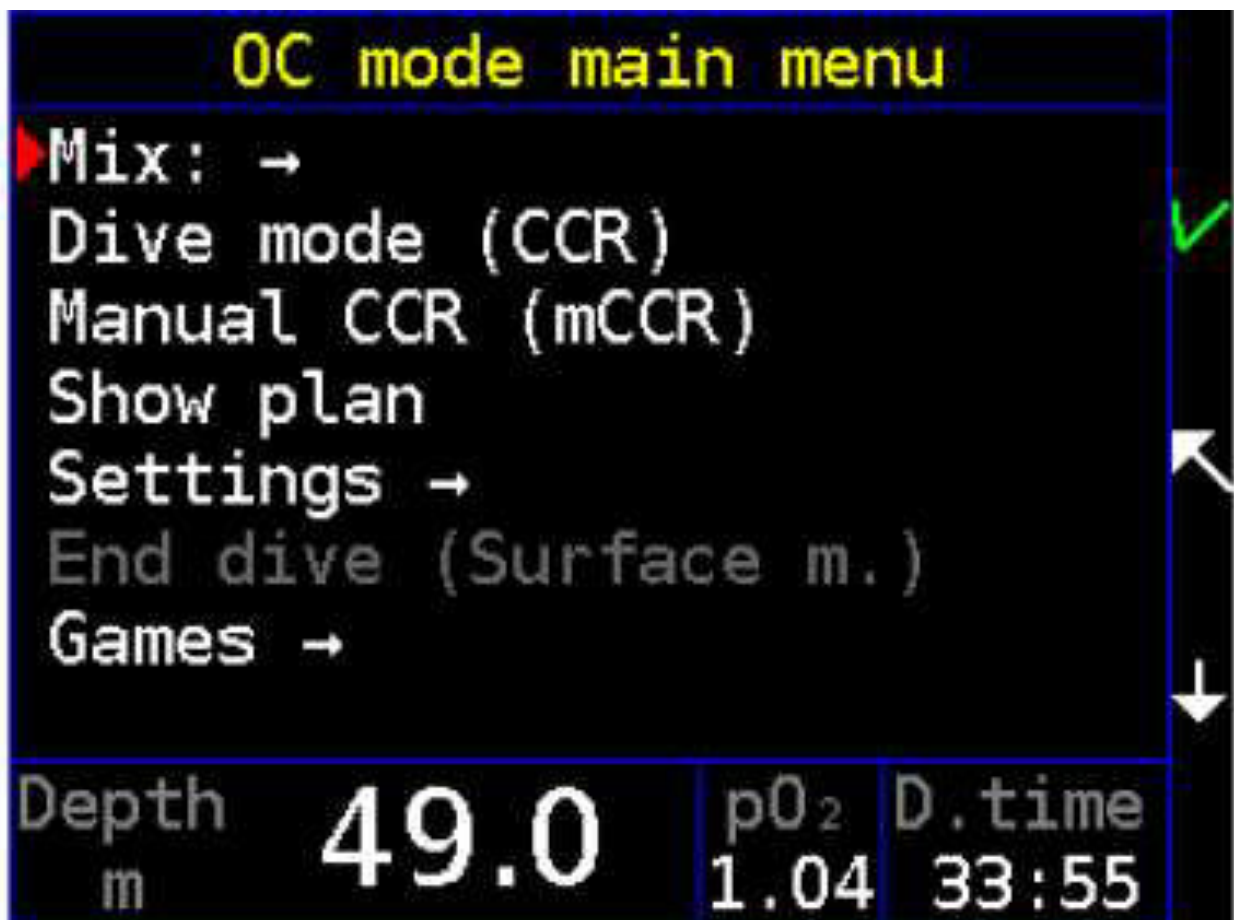

In bailout mode it is assumed that the diver will not breathe from the apparatus's breathing loop but will rather use a separate open-circuit apparatus. **Automatic ppO₂ regulation is deactivated in bailout mode**; the apparatus functions only as a decompression computer.

Due to this, you must not breathe from the unit, if it is switched to bailout OC mode

Up to eight breathing mixtures are can be available in this mode. The user can select the currently utilized mixture from the menu or can successively select individual mixtures with a long press of the upper or lower key. After switching to bailout OC mode, the configured default mixture is set.

2.8.4 Decompression

The decompression algorithm takes the partial-pressure values according to depth and the set mixture into account.

After switching to bailout OC mode, the safety level is automatically set using the bailout gradient factors (GFs). It is possible to switch between the standard and bailout GF sets in the menu without affecting the mode in which the CCR Liberty is operating. If the diver switches back to the CCR mode during the dive, the GF automatically switches back to Standard GF.

2.8.5 Specific handset control

Long press upper key – change of mixture (up according to the list, cyclically)

Long press lower key – change of mixture (down according to the list, cyclically)

2.9 Ascent plan

Ascent plan				1/2
Dpt[m]	Time	RunT	Gas	
42	2'	36'	30/28	
12	1'	40'	30/28	
9	2'	43'	30/28	
6	7'	51'	Oxygen	
Sum	14'	53'		
Depth m	49.3		D.time 0.87	33:29

In any diving mode, you can view the current ascent plan with the entire decompression course. Although Decompression is shown on the Liberty using the depth of the decompression ceiling and time to surface, the Ascent plan is displayed

in decompression stops at intervals of 3 m. The last column displays the gas with which the decompression stop is calculated

If a diver is in no-deco time, only "Free ascent" is shown.

Calculating and displaying the Ascent Plan is also affected by the Planner setup setting; in particular, the depth of the last decompression stop (whether the ascent is calculated with all available mixes), or with the current mix only. Details of settings are in section 3.1.1 Planner settings.

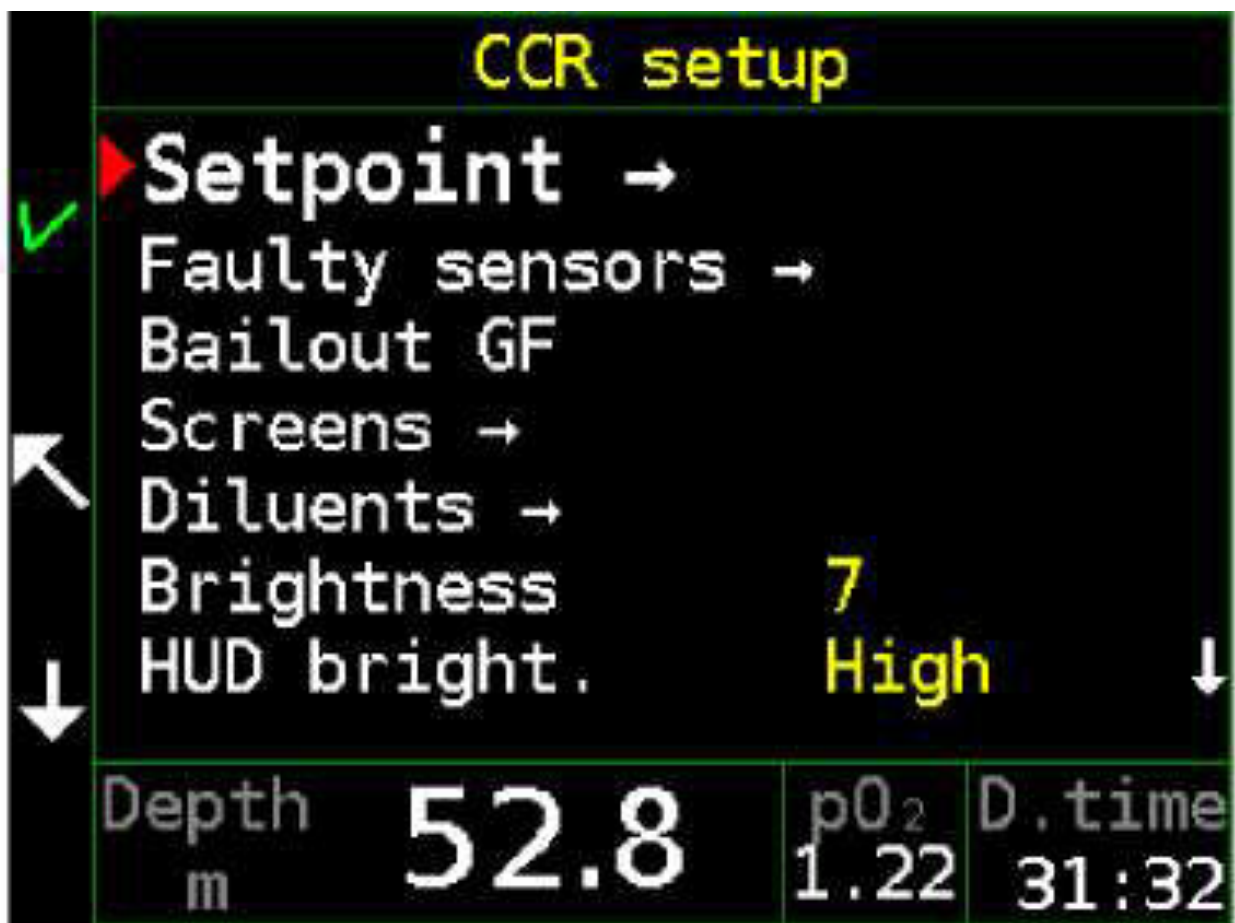

2.10 Setup in Dive mode

During the dive, many preconfigured factors can be changed, such as setting a new temporary setpoint, adding a new mix, removing a lost mixture, changing the diluent, or adjusting the brightness of the display or HUD.



Setpoint

You can set a new temporary setpoint by adding or subtracting from the value of the current setpoint. To increase the current setpoint, press +0.1, until you reach the desired setpoint. Once you have reached the desired value, move the cursor to Accept and confirm the change by pressing the upper button.

To decrease the current setpoint, move the cursor to -0.1 and press the top button repeatedly until you reach your setpoint. Once you have reached the desired value, move the cursor to Accept and confirm the change by pressing the upper button.

These setpoints are only temporary. By switching to low or high setpoint, a temporary setpoint is deleted, and the procedure described above has to be repeated to reset it.

Set high

Switch to high setpoint

Set low

Switch to low setpoint

Faulty sensors

In the event one or more sensors malfunction, it is necessary to exclude the faulty sensors from averaging. Disable the non-functional sensor or switch the oxygen measurement mode (oxygen or helium sensors). Faulty sensors would cause a poor evaluation of the unit's condition, which could have fatal consequences. The procedure for excluding and including all sensors is the same as the procedure in the surface mode – see section 2.4.8 Faulty sensors.

Bailout GF

Bailout gradient factors are used to accelerate decompression during an emergency. This reduces the safety margin to the acceptable minimum time for a safe ascent to the surface. Once the device is switched to Bailout GF, this item changes to Standard GF, which then can be used to switch back to standard gradient factors.

Screens

This feature turns some screens on or off. The procedure is the same as the surface mode setting; see Chapter 2.4.6 Preferences.

Diluents

The diluent setup feature is used to switch or set a new diluent if another diluent is used from an off-board source. In order for the diluent to be used correctly with respect to the decompression and the He-N₂ ratio, a diluent flush should be performed to replace the original gas.

Mixtures (OC mode only)

This feature can be used to edit current bailout mixtures or add a new bailout mixture. It is also possible to deselect a lost decompression bottle so it is not counted in the ascent calculation. The setting is the same as setting the blends in surface mode: chapter 2.4.3 Mixtures.

Brightness

Adjust the brightness of the display (1-10). The brightness of the display significantly affects the power consumption. To save the battery, reduce the brightness of the display to the lowest acceptable level.

HUD brightness

The HUD diode brightness can be set to 3 different levels. In very dark conditions, the full brightness of the diodes may be irritating, but in sunny shallow water the low brightness may be less visible. The intensity is adjusted by pressing the upper button.

2.11 Games

Do not disable error messages and notifications if the games are played underwater.

Make sure you maintain your position while playing during a dive. Check the pressure gauges and rebreather state on the second handset on a regular basis. Playing a game will reduce your attention. Remember: you want to dive safely, not just achieve a higher level in the game!

2.11.1 Sokoban

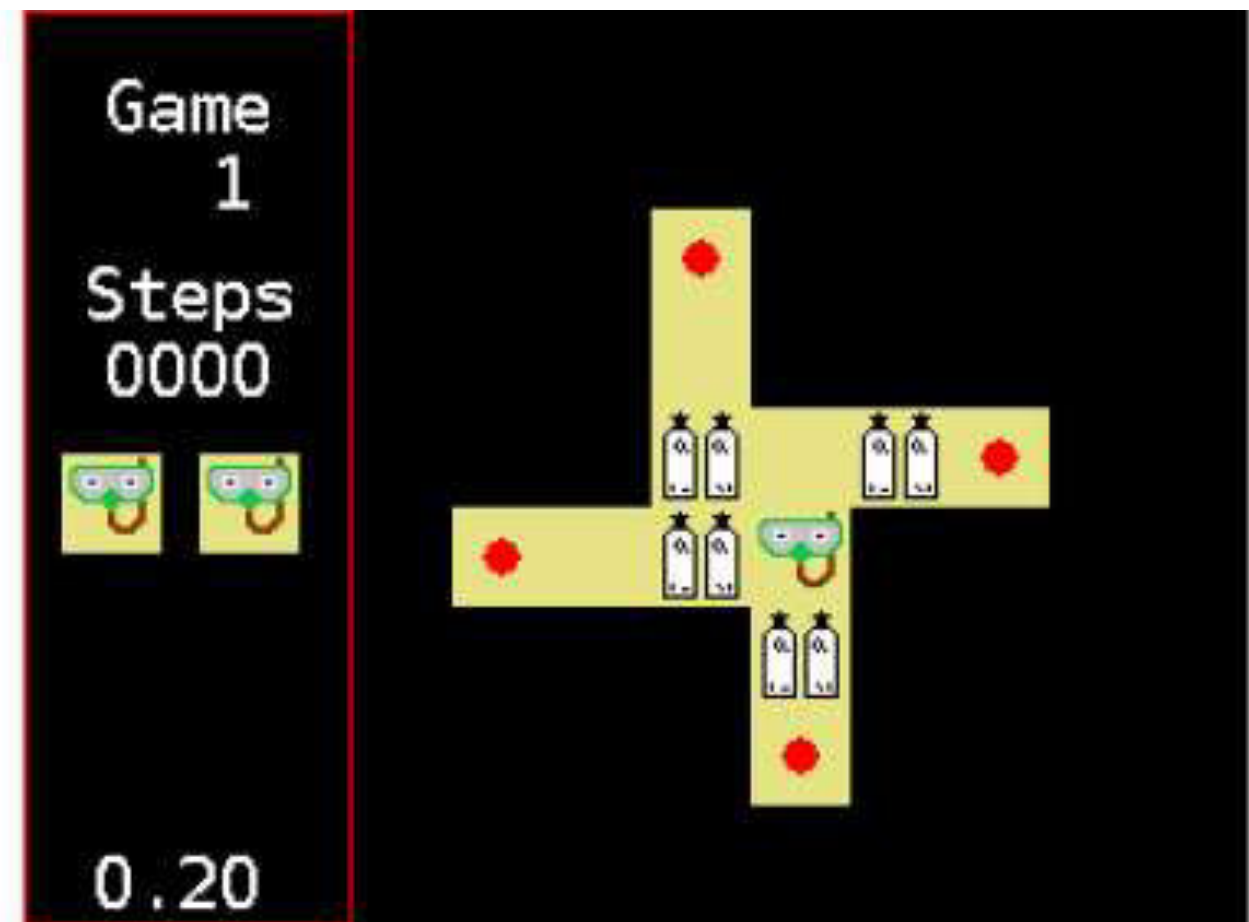

Sokoban is a type of transport puzzle, in which the player (a diving mask with snorkel) pushes tanks or crates around in a warehouse, trying to get them to storage locations (red dots).

The game is played on a board of squares, where each square is either a floor or a wall. Some floor squares contain tanks, and some floor squares are marked as storage locations.

The player is confined to the board and may move horizontally or vertically onto empty squares (never through walls or boxes). The player can also bump into a tank, which pushes it into the square beyond. Tanks may not be pushed into other tanks or walls, and they cannot be pulled. The puzzle is solved when all tanks are in the storage locations.

2.11.2 Snake

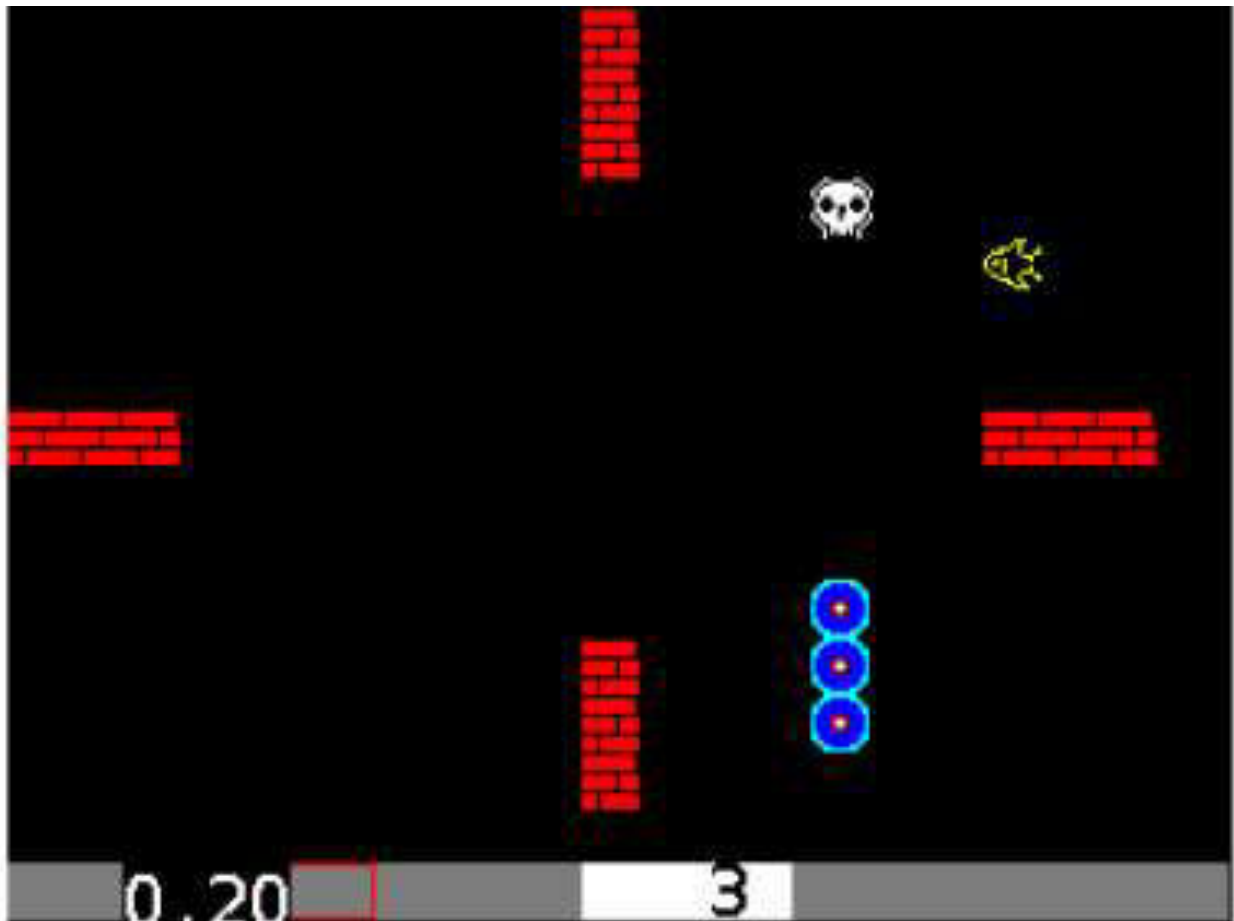

Snake is a game where the player maneuvers a line (the snake) which grows in length and is, itself, a primary obstacle.

The player controls the head of the snake. As it moves forward, it leaves a trail behind, resembling a moving snake. The snake has a specific length. The player loses when the snake runs into the screen border, a trail or another obstacle, eats poison (skull), or starves to death.

The snake can lose its length slowly (every 30 steps), and when it is too short, it dies from starvation.

The player attempts to eat fish by running into them with the head of the snake. Each fish eaten makes the snake longer, so maneuvering becomes progressively more difficult.

2.12 List of pop-up alarms and notifications on CCR Liberty

This is exhaustive list of all possible alarms and messages displayed as a pop-up on the Liberty CCR handset.

Messages are categorized according to priority, the "Critical", "High" and "Medium" are all some kind of a failure or diver error.

The "Notifications" are informative messages with the lowest priority, e.g. deco stop end, etc.

In the "Customization" paragraph is the path through menu to the relevant item with [default] option in square brackets.

Please note that most menu items are available only in surface mode, but few are available only in dive.

2.12.1 Critical priority

Low pO₂

The loop ppO₂ have fallen below the "Min pO₂" threshold. When the ppO₂ falls even further, the alarm repeats every 0.1 bar.

For example, with default settings of ppO₂ 0.3 bar, first alarm sounds at ppO₂ just below 0.3 bar, then another at 0.2 bar, and at 0.1 bar.

Customization

Setup / Alarms / Alarm Sources / Min pO₂ [0.3]

Surface mode uses fixed threshold of 0.18 bar.

High pO₂

The loop (or OC mixture) ppO₂ exceeded the "Max pO₂" threshold. If the ppO₂ keep rising, the alarm repeats every 0.2 bar.

For example, with default value of 1.6 bar, first alarm sounds just above the 1.6 bar, then at 1.8 bar, 2.0 bar etc.

Customization

CCR

Setup / Alarms / Alarm Sources / Max pO₂ [1.6]

OC

Setup / Mixtures / Max pO₂ bottom [1.4]

Setup / Mixtures / Max pO₂ deco [1.6]

Please note that internally the "Setup / Mixtures / Max pO₂ deco" equals "Setup / Alarms / Alarm Sources / Max pO₂".

Changing one will change the other as well.

PO₂ measuring lost

All O₂ sensors are malfunctioning or disabled, the Liberty has no means of reading current ppO₂.

If you are using trimix as a diluent, and have helium sensors in working order, then you can manually switch to the backup computed ppO₂ reading using helium sensors. The "pO₂ backup mode" notification will follow, and all ppO₂ values will have a blue background to signify that they are not from the chemical oxygen sensors.

Customization

Switching to backup O₂ reading:

Setup / Faulty sensors / pO₂ source [O₂]

Above ceiling

Diver is less than 1m above the calculated decompression ceiling.

Very above ceiling

Diver is more than 1m above the calculated decompression ceiling.

2.12.2 High priority

Check O₂ sensors !

This alarm occurs only if you have one or more oxygen sensors excluded, but not manually disabled. Alarm is triggered once an automatically excluded sensor exceeds the threshold for high ppO₂ alarm (see section "Critical").

This message is a clear signal for performing a sensors validation, usually by diluent flush. You are looking to confirm which sensors are faulty and which are working correctly (even the excluded ones). Once you decide that with confidence, then you can manually disable the sensors which are faulty.

There is possibility that the excluded sensor(s) is the only working one, and the rest is limiting, unable to reach the current ppO₂. This situation has happened before, and therefore is only a question of time when it will happen again.

When you are confident that the excluded sensor is indeed faulty, you can manually disable the sensor to suppress this alarm.

Please note that you can manually re-include the excluded sensor in the faulty sensors screen as well.

Customization

Manually disable and enable sensors:

Setup / Faulty sensors / Oxygen sensors

Oxygen #3 excluded

One of the oxygen sensors is deviating from the average calculated from the three other sensors by more than a 0.1 bar for at least 15 seconds. Unless disabled by diver, the sensor will be automatically enabled again, once it fits into the average for at least 10 seconds. The inclusion does not generate any alarm or notification.

Be aware that once you have one sensor excluded, the average ppO₂ is calculated from the three valid sensors. Also, any other exclusion compares one sensor to the other two, which is more prone to exclude a valid sensor if the other two become current limited.

If you want to avoid automatic inclusion of the once excluded sensor, then you can manually disable it.

Customization

Manually disable and enable sensors:

Setup / Faulty sensors / Oxygen sensors

Pressure #1 excluded

Liberty uses four sensors in total, two for each computer unit. So, although extremely rare, you may see this message.

You may see this message after damaging fine pressure sensors (marked with "F" in system check) by diving to depths of over 150m.

Customization

Manually disable and enable sensors:

Setup / Faulty sensors / Pressure sensors

Other CU down

The Liberty head contains two control units "CU", they are connected by one communication line. If one of the CUs stops responding for 10 seconds, the alarm is

raised.

If the one CU goes offline, either by a low battery or malfunction of any kind, the other CU keeps full functionality, injecting oxygen using its own solenoid. CU is limited only by having two oxygen cells, two pressure sensors, one HS.

When using only one HS in sidemount, it is advised to connect HUD to one side and a handset to the other side of the head. So even running on one CU, you keep the ability to read loop ppO₂ on either HS or HUD.

CNS O₂ toxicity 115%

The oxygen toxicity alarm sounds in three stages, at 75%, 90% and 100%. To notify the diver that he is reaching the NOAA oxygen exposure limit.

If you need to prolong your stay underwater, reaching the CNS limit, you can lower the setpoint to find a compromise between oxygen exposure and decompression time.

Customization

Setup / Alarms / Alarm Sources / CNS [On]

Stack time 240 min

The scrubber timer alarm. You can modify the notification time in surface menu according to your habits. Also, you can customize whether the timer should be active on the surface, or underwater only.

Customization

Setup / Alarms / Notifications / Stack time [150']

Setup / Alarms / Notifications / Stack timer on sfc. [On]

On ... timer running all the time when Liberty is in dive mode, even on the surface.

Off ... timer running underwater only (below 1.5m).

SLOW DOWN !!!

Ascent speed exceeded 60m per minute.

Customization

Setup / Alarms / Alarm sources / Ascent rate [On]

PO₂ emergency mode

Notification after manual switch to calculating ppO₂ from helium sensors data. See also „pO₂ measuring lost“.

Customization

Setup / Faulty sensors / pO₂ source [O₂]

Pressure sens. diff.

Only two pressure sensors are available and they differ by 1.5m or more. For example, when running on one CU and the fine pressure sensor is faulty.

Customization

Setup / Faulty sensors / Pressure sensors

Disable or enable desired pressure sensor.

Pressure #3 sensor bad

Pressure sensor value differs from the average of other pressure sensors by 1.5m or more.

Customization

Setup / Faulty sensors / Pressure sensors

Disable or enable desired pressure sensor.

High humidity CU L

It occurs when the humidity in the CU is higher than 75%.

Low battery

The battery level has reached warning level. Liberty has two batteries – one for each side, each battery then has its own alarm.

Customization

Setup / Alarms / Alarm sources / Low battery % [25]

Please note that setting the level below 10% suppresses the “Critical battery” alarm.

Furthermore, setting the alarm threshold too low, may result in warning too late to be useful.

Critical battery

The battery level has reached fixed level of 10%, the two batteries has separate alarms.

Customization

Fixed at 10% battery level.

This alarm is not customizable, though please note that setting “Low battery” warning level below 10% suppresses the critical alarm. The diver will get only the “Low Battery” alarm.

2.12.3 Medium priority

Slow down

The ascent or descent speed exceeded the set value.

Customization

Setup / Decompression / Rates & zones

Please note that ascent and descent rates are used also in the dive planner, TTS and ascent plan calculations.

BO RMT 4'

Bailout remaining time advance warning, warns about 5' before expiration. For more information see "BO RMT expired" below.

BO RMT expired

Bailout remaining time expired. This marks a point of dive when the OC bailout will just last if you begin your ascent immediately. The calculations are based upon the decompression settings, enabled OC mixtures, cylinder volumes and pressures, respiratory minute value etc.

Warning

The BO RMT is only relevant, when you have all configuration set precisely for the current dive. Especially the OC mixtures setting, having enabled other OC mixtures than you take on the dive will render the BORMT calculation invalid.

BO RMT expired CNS

Liberty FW version 2.12 and up.

Bailout remaining time for the dual CCR mode is active only when the "BOCCR settings" is enabled. This alarm is only in the Bailout CCR mode.

The last word indicates what is the limiting factor. At the moment that can be Battery, Stack and CNS.

Customization

Setup / Miscellaneous / BOCCR settings [Off]

Global Bailout CCR switch also decides whether the BO RMT calculation will be OC or CCR.

Lost Gas EAN 50

Open circuit mode only.

Notification that the best mix at this depth is marked "lost" resulting in ascent plan and TTS recalculation without the best mix. Switching to this gas will remove the "lost" tag and recalculate the ascent including the current best mix again.

This message can be caused for example by ignoring the "Switch to EAN50" at 21m notification (see below). The algorithm is 1st notification, 2' pause, 2nd notification, 2' pause and if even at this point diver did not switch to the advised gas, the gas is marked as "lost".

Customization

Setup / Alarms / Notifications / Gas sw. reminder[Off]

The "Lost gas" feature is available only when "Gas sw. remainder" is turned on.

2.12.4 Notifications

High setpoint

Setpoint change notification, automatic or manual. The automatic switch to high setpoint is configurable in menu "SPh auto".

Customization

Setup / Setpoints / SPh auto [Off]

Automatic switch to high setpoint, you may set a depth in descent, after a time or

depth in ascent.

Low setpoint

Setpoint change notification, automatic or manual.

Automatic switch to setpoint low is possible only when using descent setpoint feature. With the descent setpoint active, the Liberty will automatically switch to low setpoint once the loop ppO₂ reach the low setpoint, or after 10' from submersion.

Customization

Setup / Setpoints / Use descent SP [Off]

Setup / Setpoints / ppO₂ descent [0.4]

Setpoint 1.1

Setpoint change manual, immediately after setting custom SP.

Customization

Setup / Setpoint / Accept

Custom setpoint is available in dive mode only.

Mode BO CCR

Manual or automatic mode change notification – OC, CCR, mCCR, BO CCR.

Automatic mode change is possible only from BO CCR to CCR, when the loop ppO₂ falls 20% below the diluent ppO₂ at current depth. For example, when the diver starts breathing from the unit in the BO CCR mode, without changing mode to CCR.

Please note that this is intended as an emergency feature only.

No deco end

End of the no-decompression part of the dive.

Customization

Setup / Alarms / Notifications / No deco end [On]

Depth 55 m reached

Custom depth notification, diver can set three depth notifications for descent, and three for ascent.

Customization

Setup / Alarms / Notifications / Depth & Time

Time 33' elapsed

Custom elapsed dive time notification, diver can set three different notifications.

Customization

Setup / Alarms / Notifications / Depth & Time

Bookmark 3

Notification that user bookmark has been saved to dive log.

Customization

Applications / Add bookmark

This item is available in dive mode only.

Switch to EAN50

Open circuit only.

Notification for a gas change based on current depth, available mixtures and set

maximum ppO₂.

Customization

Setup / Alarms / Notifications / Gas sw. remainder [Off]

EAN50

Open circuit only.

Switched to an OC mixture, automatic notification immediately after gas switch in menu as a confirmation of a successful gas switch.

Diluent TMX 10/50

Switched to a different diluent, automatic notification immediately after a diluent switch in menu as a confirmation of a successful diluent switch.

Factory defaults

All user settings have been reset to factory defaults.

Customization

Setup / Miscellaneous / Factory defaults

[< Previous page / Section: 1. Technical design](#)

[> Next page / Section: 3. Procedures](#)

Section: 3. Procedures

3.1 Dive plan

3.1.1 Planner settings

3.1.2 Planning

3.2 Dive preparation

3.2.1 Replacement of CO₂ sorbent

3.2.2 Assembling the rebreather body

3.2.3 Mounting the rebreather body

3.2.4 Attaching the counterlungs and hoses

3.2.5 Tank filling

3.2.6 Battery charging

3.2.7 Helium sensor calibration

3.2.8 Calibration of the oxygen sensors

3.2.9 Preparing the bailout apparatus

3.2.10 Setting parameters

3.2.11 Directional valve check

3.2.12 Physical inspection

3.3 Pre-dive inspection

3.3.1 Internal testing of the control units

3.3.2 Pressure sensor test

3.3.3 Comparison of oxygen sensors and their calibration

3.3.4 Helium-sensor test

3.3.5 Battery testing

3.3.6 Solenoid testing

3.3.7 HUD inspection

3.3.8 BD inspection

3.3.9 Negative pressure test

3.3.10 Positive pressure test

3.3.11 IP Pressure

3.3.12 Pre-dive checklist

3.3.13 Pre-breathe

3.4 Diving

3.4.1 Breathing high oxygen content gases

3.4.2 Putting on the apparatus

3.4.3 Using the DSV

3.4.4 Monitoring of devices

3.4.5 Switching to CCR mode

3.4.6 Water entry

3.4.7 Submersion

3.4.8 In-water check

3.4.9 Descent

3.4.10 Controlling buoyancy and trim

3.4.11 Mask clearing

3.4.12 Increased physical exertion

3.4.13 Ascent

3.5 Post-dive procedures

3.5.1 Immediately after surfacing

3.5.2 CO₂ scrubber maintenance

3.5.3 Cleaning and disinfection

3.5.4 Battery care

3.5.5 Dive log download

3.5.6 Long-term storage

3.6 Emergency procedures

3.6.1 Emergency ascent (bailout)

3.6.2 Oxygen-source malfunction

3.6.3 Diluent-source malfunction

3.6.4 Scrubber malfunction

3.6.5 Inadvertent release of the mouthpiece

3.6.6 Flooding

3.6.7 Loss of buoyancy

3.6.8 Rescue on the surface

3.6.9 Malfunction of oxygen-concentration measuring

3.7 Maintenance

3.7.1 Tools and replacement parts

3.7.2 Detection of leaks

3.7.3 Regular service inspection

3.7.4 Long-term maintenance

3.7.5 Firmware update

3.8 Transport

3.8.1 By car

3.8.2 By boat

3.8.3 By plane

3. Procedures

3.1 Dive plan

For planning a dive in the strict sense (gas management and decompression) the internal functions of the CCR Liberty can be used. The planner calculates a dive plan in CCR mode or with an emergency bailout on open circuit. To compute the decompression, the Bühlmann ZHL-16B algorithm (with adjustable gradient factors) as well as, an on-line decompression calculation is used.

3.1.1 Planner settings



To simplify the planner control, the planner takes all set values as setpoints, breathing mixtures, gradient factors, and ascent speed from device settings. For the correct calculation of the plan, it is therefore necessary to set these items exactly as they will be used for the real dive.

Particularly in the case of breathing mixtures for bailout, it is necessary to check only those mixtures which are actually available during the dive and to make sure their composition, pressure, and cylinder parameters are set correctly. If any other mixtures are checked or mixtures have a larger gas reserve set, they will be included

in the planning and will cause serious distortion to the dive plan, which may have tragic consequences.

A detailed guide for setting these parameters can be found in the following sections:

2.4.2 Setpoints

2.4.3 Mixtures

2.4.4 Decompression

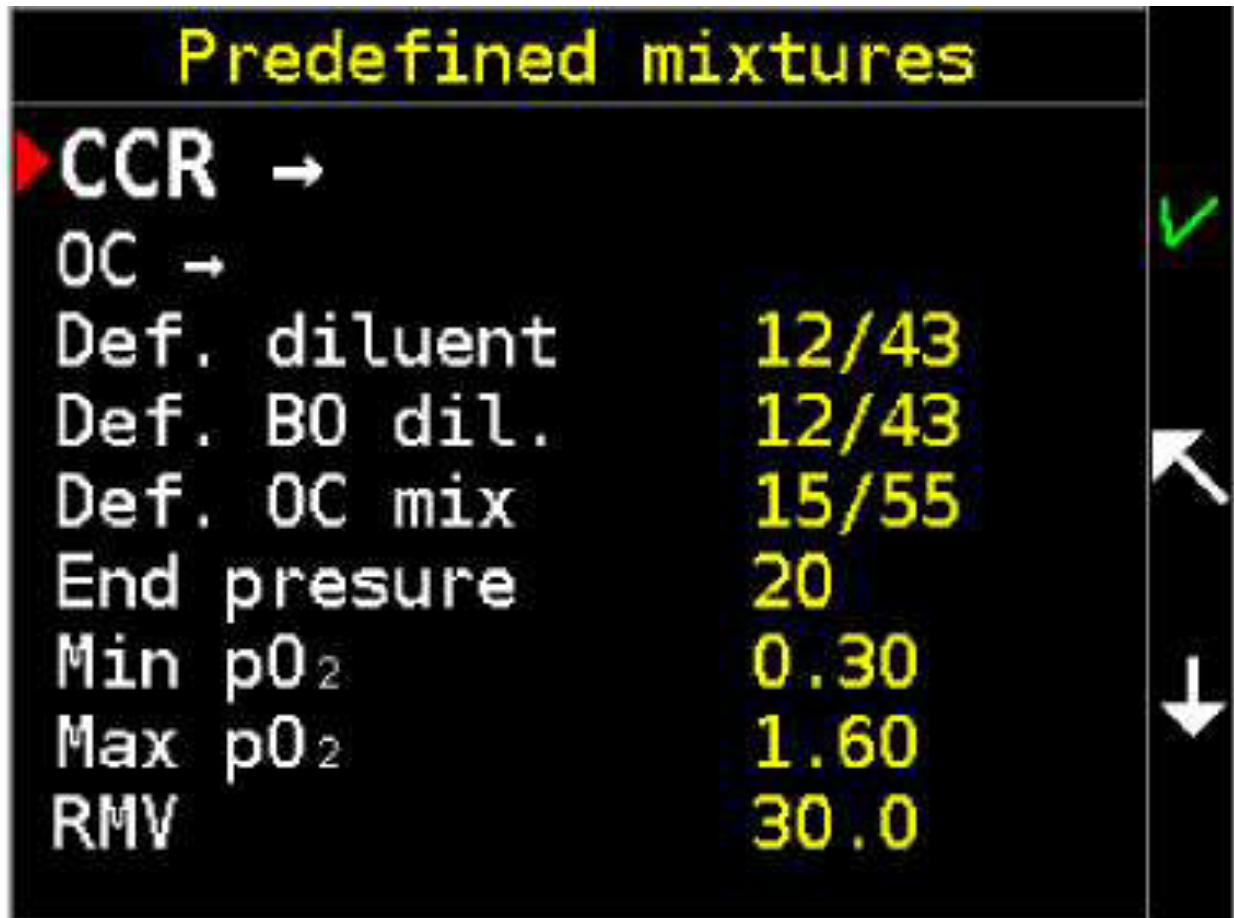

Predefined mixtures	
▶ CCR →	
OC →	
Def. diluent	12/43
Def. B0 dil.	12/43
Def. OC mix	15/55
End pressure	20
Min pO ₂	0.30
Max pO ₂	1.60
RMV	30.0

In mixture settings, note the Respiration minute volume expressed in liters per minute (l / min) or in cubic feet per minute (cu ft / min). We recommend that you choose a sufficient reserve for a crisis situation. During a CO₂ hit (hypercapnia), 78 a diver's ventilation can exceed 50 l / min (1.8 cuft / min). For details on the planner settings, see Menu / Setup / Decompression / Planner setup

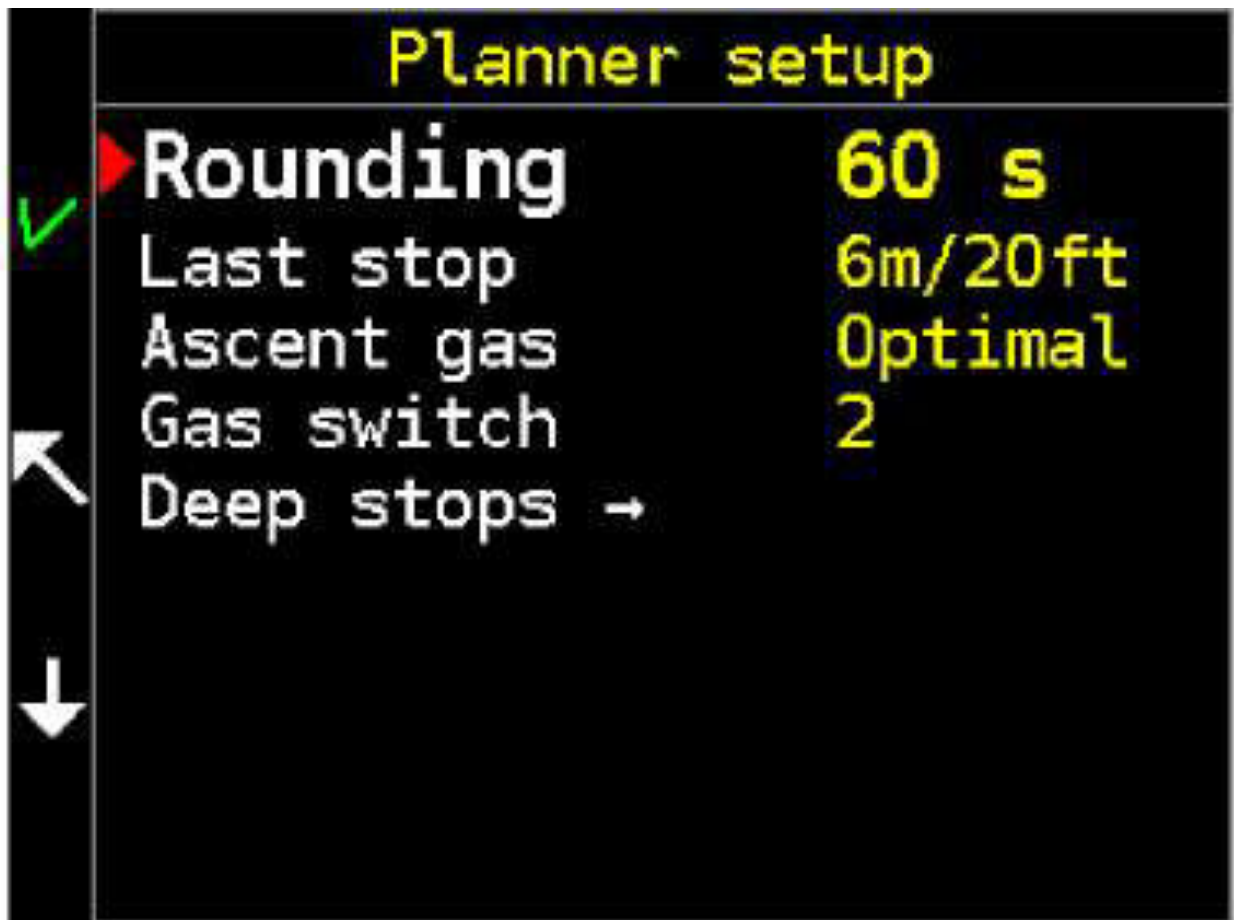

Rounding

Here you can set the decompression rounding time to 60 seconds, 30 seconds or 1 second

Last stop

This specifies the depth of the last planned stop at 3 m (10 ft) or 6 m (20 ft)

Ascent gas

Determine whether you want to plan the bailout ascent using all of the set gases, the Optimal option, or only one current gas. The most widely used gas in the planner is the Current option. This setting also influences the TTS calculation during the bailout of the output. It is either planned with all available mixes (optimal) or just current (current).

Ascent SP" [High] / [Current]

Setpoint with which the scheduler counts the output (from the end of bottom time). Current is a low setpoint setting. Use this option if you want to dive with a low SP for the entire dive, or simply want to see a TTS with a current setpoint instead of a high SP.

Gas switch

Select this option to set the minimum switching stop length for open circuit bailout ascent. In this stop the diver tries to use the high ppO_2 and the oxygen window effect when changing the mixture. The stop depth is set automatically according to the ppO_2 mixture. The ascent ppO_2 1.6 is used. If the stop is deeper than the first decompression stop, a separate stop is created and is included in the ascent and gas consumption plan. If the depth is in the step decompression zone, the setting determines the minimum stop length. The numeric value represents the length in minutes. If a zero value is selected, the stop is not counted.

Deep stops

Here you can include extra deep stops to reduce silent bubbles. Richard Pyle's calculation procedure is used to halve the pressure between the start of the ascent and the depth of the first decompression stop. In this option, it is necessary to consider setting the gradient factors so that the medium and slow tissues are not saturated.

3.1.2 Planning

In the scheduler, choose a planning mode (CCR / Bailout).



Liberty allows the plan to be calculated on each handset separately, so the user can simultaneously plan for the entire dive on the rebreather and an emergency plan with a bailout ascent on the second handset. Just set the surface interval, target depth, and bottom time. Bottom time includes the descent time.



For multiple diluents, select the diluent that is going to be used on the bottom.

Surface interval is the planned time spent on the surface after the dive. This value is entered to account for the residual tissue saturation from previous dives and the rate of desaturation during the surface interval.

Dive plan CCR Bailout 1/4	
Surface int:	60'
Depth:	70 m
Duration:	30'
Bailout gas:	TMX 15/55
	Insufficient gas
Nodeco:	0'
TTS:	100'
Total:	130'
CNS:	62
NoFly:	4:32

After entering all values, select Plan dive.

In the case of CCR dive planning, a summary of the planned dive information (surface interval, target depth, bottom time, diluent) is displayed.

No deco – Time with no decompression at the bottom with the current mixture

TTS – “Time to surface” total ascent time

Total – total dive time

CNS – accumulated exposure of CNS for planned dive

NoFly: – Expected time limit of flying after surfacing

In addition, when planning a bailout mode, an “Insufficient gas” warning may appear if the specified amount of gas is not sufficient to complete the open circuit ascent.

Press the bottom button to go to the next page. Use the top button to return to the previous page.

Dive plan CCR Bailout 2/4		
Gas	litres	bar
↑ 15/55	540	45
30/28	4258	355
↖ Oxygen	1932	351
↓		

The second Bailout screen – “gas management” shows the individual gases used and their consumption in liters (cu ft) and bars (PSI). If the pressure exceeds the limits of the cylinder, it is red. In this case, it is necessary to add another gas to the dive plan. If you do not have additional gas available, shorten the bottom time or reduce the target depth.

Dive plan CCR Bailout 3/4				
	Dpt[m]	Time	RunT	Gas
↑	70	30'	30'	15/55
	42	2'	34'	30/28
	33	1'	36'	30/28
↖	27	1'	39'	30/28
	24	2'	42'	30/28
	21	3'	46'	30/28
↓	18	4'	51'	30/28
	15	7'	59'	30/28

Avoid reducing the RMV value, as the dive plan should always be done with possible crisis situations where increased gas consumption is anticipated.

If your gas management is OK, press the bottom button to go to the next page.

Dive plan CCR Bailout 4/4			
Dpt[m]	Time	RunT	Gas
12	9'	69'	30/28
9	17'	87'	30/28
6	40'	128'	Oxygen
Sum	95'	130'	

The left column (Dpt) shows the depths of each step, including bottom time (yellow). The second column (Time) determines the time spent at a specific depth. The third column (RunT) represents the current dive time at the moment of leaving a given depth. The fourth column (Gas) determines which gas is to be used at a given depth. Gases are color-coded.

Helium blends are labeled brown, nitrox mixtures are green (various tints by amount of oxygen), air or diluent is white, oxygen is blue.

If the plan is longer than 8 steps, the plan is continued on the next page. The summary is expressed in pink. The first number represents the total time of the ascent, and the second number represents the total time of the entire dive.

3.2 Dive preparation

3.2.1 Replacement of CO₂ sorbent

Sorbent service life

Continually keep records of the extent of scrubber consumption. Set a stack time warning, and don't forget to reset the stack timer after replacing the sorbent. If ever in doubt, replace the sorbent.

The recommended scrubber filling material is Sofnolime 797 sorbent (producer: Molecular Products). The cartridge holds approximately 2.5 kg of sorbent.

The maximum safe operating period of the sorbent is 168 min, determined by a test in accordance to EN 14143:2013 (Article 6.6.2). During the test, 1.6 l/min of CO₂ were added to the breathing loop with a ventilation rate of 40 l/min and an exhalation temperature of 32±4 °C; the unit was submerged in 4 °C water to a depth of 40 m with a ppCO₂ of 5mBar (test provided by Life Support Test Facility – LSTF 0916). This is the worst case scenario, and it considers a very high level of body exertion, with oxygen consumption of 1.78 l/min.

Typical oxygen consumption for scuba diving ranges from 0.4 l/min for a diver in rest using a DPV (Smith, 2008) to 1.2 l/min for moderate work.

In normal conditions scrubber duration can be considered to range from 4 h in deep cold water with moderate work to 6 hours for an easy dive.

	O ₂ consumption (l/min)	CO ₂ production (l/min)	Scrubber duration (hh:mm)
Diver in rest	<0.5	<0.5	>8
Easy dive, experienced diver	0.8	0.7	6
Mild work	1.0	0.9	5
Moderate work	1.2	1.1	4
EN 14143	1.78	1.60	2:48

The physiological limit is not ppCO₂ 5 mBar, but ten times higher (Knafelc, 2000). A respiratory quotient 0.9 is too high; a more realistic estimate is 0.8-0.85. Sorbent service life is longer (or safety margin is bigger) than previously stated.

In the course of the sorbent's service life, it is allowed to remove the scrubber cartridge a maximum of two times (see section 3.5.2 CO₂ scrubber maintenance).

Sorbent replacement procedure

Handle the sorbent in accordance with the manufacturer's instructions. Comply with all safety instructions and use protective gear. Take environmental protection into account when disposing of used sorbent.

Remove all of the old sorbent content from the cartridge.

If you disinfect the rebreather, proceed according to section 3.5.3 Cleaning and disinfection. It is preferable to disinfect after a dive rather than waiting for a longer period.



Place the scrubber cartridge on a clean surface. Handle it with clean, thoroughly washed hands. We recommend using disposable surgical gloves. Dirtying the cartridge can contaminate the breathing circuit and cause infection. A seemingly clean surface can be contaminated with microbes, especially in tropical and subtropical conditions.

If you cannot ensure the cleanliness of a surface, place the cartridge on a clean towel.

Follow these hygienic principles when filling and handling the scrubber in any way.

If you are working outside (recommended) and there is, at the least, moderate wind, stand sideways to the wind and pour the sorbent slowly into the cartridge from a height of approximately 20-30 cm (1 ft). Allow the wind to remove the finest dust particles.

If you are working indoors, pour the sorbent into the cartridge from a minimal height. Sorbent dust is aggressive and can cause corrosion. Therefore, we do not recommend working with the scrubber inside of an automobile, for example.

In order to prevent the sorbent from falling into the central tube, place the canister's metal disc lid over the opening, or plug it by other suitable means. Pour sorbent into the cartridge until it is approximately one-third full. Then gently lift the cartridge, and allow it to fall three times from a height of approximately 1 cm (1/2"). Repeat this process when the cartridge is two-thirds full and again when it is completely full. The cartridge is completely full when the sorbent reaches a level between the min and max lines marked on the central tube.

After filling, place the metal disc and spring-loaded pressure plate on top of the sorbent. Then remove the pressure plate and lid, and verify that the surface of the sorbent is levelled and that no channels have formed. Place the metal disc and spring-loaded pressure plate on top of the sorbent again; press down and secure the assembly with the retaining ring. The retaining ring must fit into the slot on the pressure plate.

If the cartridge is not filled sufficiently, a gap of less than 6 mm or less will remain between the edge of the lid and edge of the metal mesh. In such a case, add sorbent and then shake and close the cartridge according to the procedure described above.

If the cartridge is overfilled, there will be a gap greater than 17 mm between the edge of the lid and the edge of the metal mesh, and it will not be possible to insert the retaining ring without excessive force. In such a case, remove the excess sorbent with a clean teaspoon or any other suitable tool. Shake the cartridge, and close the lid again.

Before inserting the cartridge into the scrubber canister, check to ensure that the water trap is dry. If that is not the case, remove the water trap, and dry it with a towel.

After each scrubber change, the stack timer Menu / Pre-dive / Stack time reset must be reset

The stack timer measures the use of the scrubber by simply counting the time spent in the dive mode. You can adjust whether stack time is calculated on the surface or not.

Sorbent dust damages textiles, especially polyamide and cotton fabrics. Therefore, after working with the scrubber, immediately wash the towel on which the cartridge was placed and all clothing that was exposed to sorbent dust.

Do not work with sorbent in the vicinity of load-bearing straps, ropes, or even metal mountain climbing or speleological equipment. In the event of possible exposure to sorbent, ropes and load-bearing straps should be discarded immediately, as their loading capacity can deteriorate significantly.

Condition of the scrubber before submersion

The scrubber must have sufficient absorption capacity for the planned dive.

The sorbent must contain some amount moisture so that the chemical reactions that enable the scrubber to remove CO₂ from the breathing mixture can take place. This means that the scrubber cannot be completely dry or frozen.

In freezing weather, stow the rebreather in a warm space prior to the dive. If you are outside with the apparatus and a delay happens, maintain the temperature of the sorbent by breathing from the apparatus.

3.2.2 Assembling the rebreather body

Mount the head on the CO₂ scrubber canister.



When mounting the head, push the scrubber canister pin into the opening on the head, and close the head.

Press on the head from above so that it is fully seated. If a lot of force is required to completely close the head, apply a small amount of lubricant to the O-ring on the neck of the head. You can also choose an O-ring with a smaller cross section diameter.

3.2.3 Mounting the rebreather body

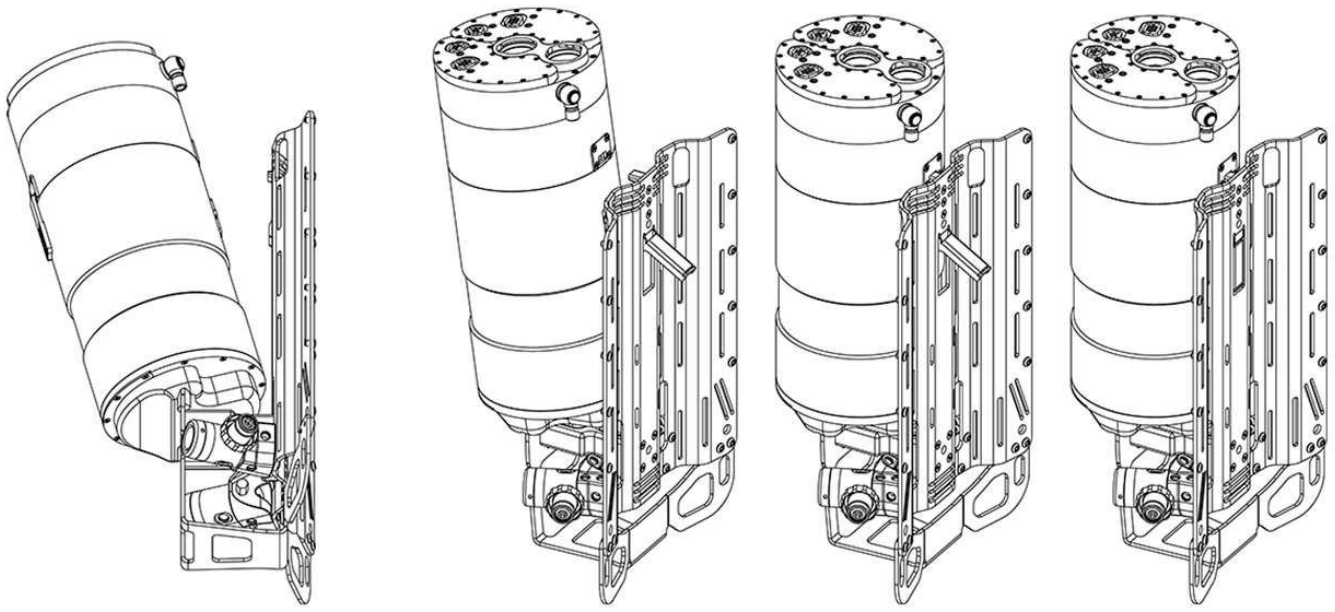

Procedure:

1. Mount the body of the apparatus on the frame so that the recesses in the lower part fit into the protrusions on the base.
2. Lift the lever in the center of the backplate.
3. Press the rebreather body against the backplate so that the tongue in the upper part of the backplate fits into the recess in the head of the apparatus. If necessary, forcefully press the top of the head downward.
4. Press down on the lever in the middle of the apparatus and check whether the lock is closed.
5. Check whether the apparatus is firmly attached.
5. Secure the body with the securing strap.

3.2.4 Attaching the counterlungs and hoses

The position of the counterlungs in relation to the diver's body determines the work of breathing. Adjust the position by shifting the upper strap on the back side of the counterlung.

Procedure:

1. Attach the counterlungs using the buckles so that the T-piece bulkheads are roughly at shoulder level and the flaps with Velcro are facing the center (toward each other).
2. Connect the manual diluent bypass valve to the lower bulkhead of the left breathing bag.
3. Connect the overpressure valve to the lower bulkhead of the right breathing bag.
4. Connect the manual oxygen bypass valve to the middle bulkhead of the right breathing bag.
5. Attach the inhalation T-piece (without the partition) to the upper bulkhead of the left breathing bag.
5. Attach the exhalation T-piece (with the partition) to the upper bulkhead of the right breathing bag.
7. Attach the terminal elbow of the inhalation (left) corrugated hose to the opening in the center of the head.
3. Attach the terminal elbow of the exhalation (right) corrugated hose to the opening on the edge of the head.
9. Screw the short oxygen hose to the 9/16" elbow on the side of the head. Tighten the union nut firmly by hand.
3. Route the LP hoses to the ADV and to the manual diluent bypass valve and the HP hose to the diluent pressure gauge so that they pass together over the shoulder strap from the outside to the inside of the strap.
1. Attach the ADV to the middle bulkhead of the left counterlung.
2. Attach the quick-release connector of the LP hose to the manual diluent bypass valve.
3. Straighten the hoses and secure them under the Velcro flap of the left breathing bag.
4. Route the LP hose to the manual oxygen bypass valve, and the HP hose to the oxygen pressure gauge so that they unit pass together over the shoulder strap from the outside to the inside of the strap.
5. Attach the quick-release connector of the LP hose to the manual oxygen bypass valve.

5. Straighten the hoses and secure them under the Velcro flap of the right breathing bag.
7. Route the LP hose of the buoyancy control device (BCD) under the first rubber band on the corrugated inflator hose of the BCD, then under the rubber band on the left shoulder strap above the D-ring, and finally under the second rubber band on the corrugated inflator hose.
3. Connect the quick-release connector to the inflator of the BCD.
9. Adjust the position of the BCD inflator hose so that it is easily accessible when diving.

For attaching devices to the connectors, see also

section 1.3.1 Corrugated hoses

section 1.3.3 Connection to the breathing bags

section 1.4 Inhalation bag

and section 1.5 Exhalation bag

3.2.5 Tank fillings

When filling the tanks with the breathing mixture, follow the procedures and rules with which you were familiarized in a technical gas blending course (trimix blender, etc.). If you have not successfully completed such a course, leave mixture blending to a qualified person.

When handling oxygen, follow the procedures and rules with which you were familiarized in a trimix course and, subsequently, in a CCR Liberty course. If you have not successfully completed such a course, do not handle the CCR Liberty.

Diluent

Choose a diluent that is able to flush a high oxygen mix from the breathing loop. Prepare the diluent so the partial pressure of oxygen will be 0,2 bar lower than the planned setpoint at the greatest depth of your planned dive. Partial pressure of nitrogen should not exceed 4 bar (3.2 bar is recommended).

In regards to oxygen compatibility and cleanliness for oxygen service of the parts working with diluent, do not exceed an oxygen concentration of 21% ($\pm 1\%$) in the diluent. Minimum oxygen concentration is 5%.

Diluent contamination should not exceed the limits given by the standard EN 12021 Section 6.2 when using compressed air for the unit.

Make sure that the diluent was filled by a compressor with properly maintained filters. Alternatively, you can use an personal filter. When using a compressor with a combustion engine, ensure that the exhaust gases from the engine cannot get into the compressor intake.

Mixtures with higher helium present more advantages for a number of reasons. But a low O₂ mix on the surface in shallow depths, with a lack of breathability, significantly increases risks.

After filling, write the mixture composition with a permanent marker on a label (piece of duct tape) and attach it to the tank.

The consumption of diluent depends on the dive profile, frequency, and extent of depth changes. Diluent capacity is not limited by time but by the dive profile. This should be taken into account especially when planning dives in caves. Diluent is consumed mainly during the descent. During the ascent there is a zero theoretical consumption, and any practical consumption is mainly due to mask clearing.

Based on a practical experience, the typical diluent consumption during a simple dive to a depth of 100 m is approximately 50 to 70 bar. This usually does not increase by staying longer at the same depth.

Always keep a sufficient safety margin (at least 50 bar) to cover unplanned situations. If the pressure in the diluent tank is lower than 70 bar, not even a brief dive should not started.

According to the standards to which the CCR Liberty is CE certified and designated, do not dive to depths greater than 100 m. Therefore, the CCR Liberty is CE certified to

100 m.

Oxygen

Use oxygen intended for breathing. Oxygen contamination shall not exceed the limits given by the standard EN 12021 Section 6.2 when using compressed air for the unit.

We recommend using oxygen with a purity of at least 99.5%.

Oxygen consumption for gas duration calculations is 1.78 l/min according to the EN 14143. When considering the initial tank pressure of 200 bar and a final pressure of 50 bar in the tank, the oxygen supply suffices for 253 minutes. In this calculation, oxygen contained in the diluent is not considered.

These conditions correspond to high levels of physical effort during a dive. If a diver is calm during a dive, consumption significantly decreases, and the quantity of oxygen and the sorbent service life is extended. A dive plan that relies on an entire dive being a low-effort dive is inaccurate.

In any case, an oxygen tank filled to 200 bar is sufficient for a dive, which greatly exceeds the duration of the CO₂ scrubber.

If the pressure in the oxygen tank is lower than 70 bar, not even a brief dive should be started.

According to the valid technical standards, filling oxygen to an operating pressure greater than 200 bars is prohibited.

3.2.6 Battery charging

Before charging the batteries, remove the jumpers from the sockets.

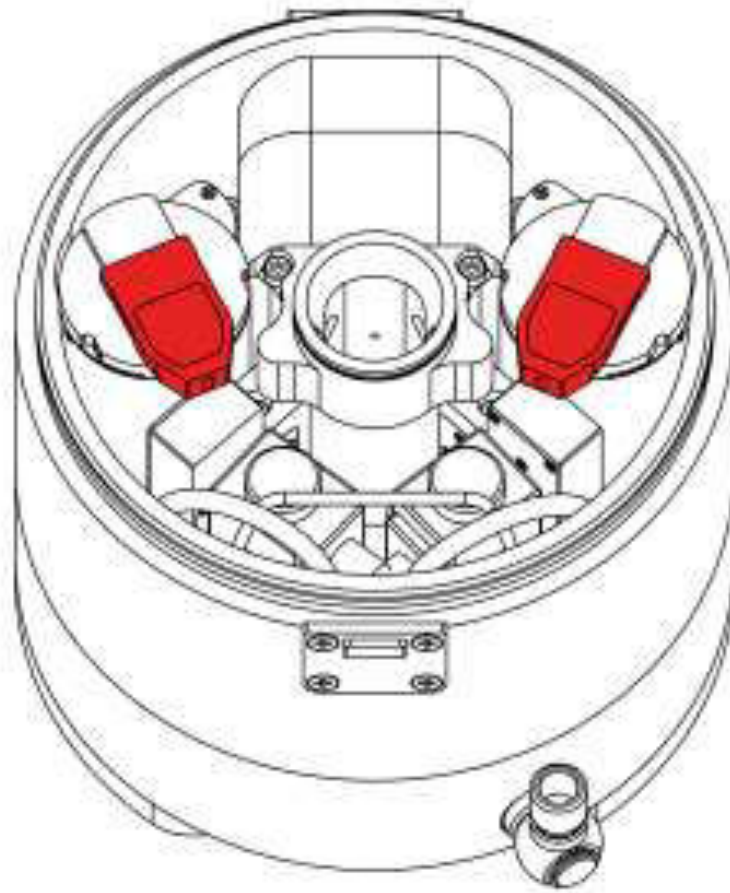

We recommend charging the batteries to full capacity one week or less before diving. Before a brief dive (up to one hour), it is permissible to store fully charged batteries for up to one month.

Do not completely discharge the batteries before charging. The service life of the batteries is extended by frequent charging.

For charging the batteries, use the enclosed charger or any USB charger dimensioned to 2 A (most chargers used with vehicle power outlets are not sufficiently dimensioned). Fully discharged batteries require approximately eight hours of charging.

Charging from a computer's USB port is possible, though charging is done with a significantly lower current. The time required for charging fully discharged batteries in this manner is approximately 15 hours. Charging from a computer's USB port can be done via an adapter connected to the external connector of the handset.

In you prepare the CCR Liberty for diving no more than one week after charging, insert the jumpers so that their pins are inserted into the connector. The rebreather will

thus be switched to standby mode, and it will be possible to switch on the control unit using the handset. If the jumpers are inserted in reverse position with the pins outside; in this position, the power supply is completely disconnected, and the control unit cannot be switched on. The Liberty 2021 edition can be stored for up to half a year with the jumpers connected. During this time the batteries will discharge to about 50%.

A 30 sec switch-off timeout is active during charging. The timeout is prolonged by pressing a button in editor, but not by tilting. Do not alter the settings while charging, because the unit may switch-off suddenly.

3.2.7 Helium sensor calibration

For proper helium measurement in the loop and indirect oxygen measurement, it is necessary to calibrate the helium sensors before their first use or if the measurement values are inaccurate.

Before calibration, make sure only air and no other gas is present in the inlet chamber of the helium sensor (inside the head) and that the helium sensors are not contaminated with moisture.

Select Menu / Setup / Calibration / Calibrate He – Air

The measured speed of sound should approximately be around 0.5500 ms. Start the calibration by pressing the start button. After the sensors stabilize, press the upper "Accept" button again.

3.2.8 Calibration of the oxygen sensors

Insert the measuring probe into the inhalation opening (in the center of the head). The head can be mounted on the scrubber canister, but is not required. Connect the flow limiter to the oxygen hose quick-release.

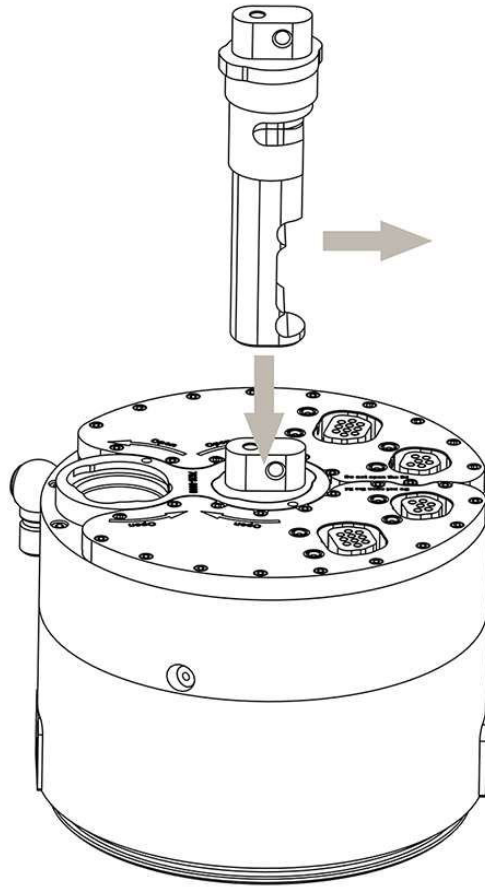

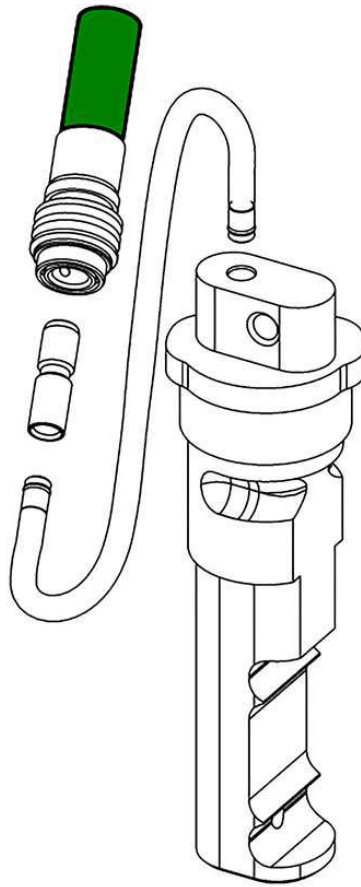

The hissing sound that accompanies the flow of oxygen can barely be heard in a quiet environment. The flow becomes more apparent if one uses a moistened finger to cover the discharge aperture. Connect the sampling tube between the flow limiter and measuring probe.

Procedure:

1. Start O₂ sensor calibration on HS in PreDive → Calibration O₂
2. Wait for mV stabilization (this could take a while)
3. Start calibration
4. Save

During calibration, the status of a sensor's service life is also determined.

At higher altitudes above sea level, the partial pressure of oxygen in the calibration mixture decreases in proportion to lower atmospheric pressure. The CCR Liberty measures atmospheric pressure and takes it into account during calibration. Therefore, do not perform any corrections at higher altitudes above sea level.

3.2.9 Preparing the bailout apparatus

The bailout apparatus must ensure a reliable return to the surface at any time during a dive.

The standard solution is to use a corresponding number of stage and decompression tanks with mixtures according to depth, distances, and the bailout plan. For a deep diving backup, it is recommended to use a mixture rich in He, regardless of the financial costs. The mixture will probably not be used for many dives. A higher content of He results in less negative buoyancy, which makes transporting the tank under water more convenient.

Preparation of the bailout stage tanks is similar to that of open-circuit diving with trimix. When planning and preparing, proceed according to the rules with which you were familiarized in a trimix course.

3.2.10 Setting parameters

Set or check the settings of all dive parameters.

For a detailed description, see section 2.4 Setup.

3.2.11 Directional valve check

The purpose of this test is to detect possible leaks in the directional valves of the dive/surface valve (DSV). This type of leakage could seriously endanger the diver. It is

not possible to assemble the complete breathing loop in the wrong direction, but the diver has to be sure that this part is not missing or leaking.

Procedure:

1. Put the bayonet socket cover on both T-pieces.
 2. Cover the left (inhale) elbow.
 3. Place the mouthpiece in your mouth, open the DSV and try to inhale. Inhaling should not be possible. The left corrugated hose collapses. Exhaling should be possible.
 4. Close the DSV, and check for leakage (the corrugated hose should stay collapsed).
 5. Open the DSV, unplug the inhale elbow, and cover the right (exhale) elbow with bayonet socket cover.
 5. Inhale from the mouthpiece, and try to exhale. Inhaling should be possible.
 7. Pull the exhalation elbow to extend the corrugated hose on the right side. Check for leakage (the corrugated hose stay extended).
- If some leakage occurs, change the directional valves or do not dive.
-

3.2.12 Physical inspection

Check to ensure that the CCR Liberty is complete, correctly assembled, and mechanically undamaged.

If the CCR Liberty is operated within an organization where someone other than the diver is responsible for the physical preparation of the apparatus, we recommend providing them a list of detailed organizational rules. An assembly checklist in editable form is prepared for download on the divesoft.com website.

3.3 Pre-dive inspection

Yes

This action temporarily
halts ppO₂ control.

Pre dive check?

No

The pre-dive inspection (PDI) procedure can be started in surface mode. Testing is conducted immediately before the dive with a fully assembled rebreather with the control units switched on.

To start the test, select Menu/Prediver/Prediver check.

The user confirms the results of the individual inspection steps:

OK — test result is positive top button; press the top button to continue.

FAIL — partial test failure, but the other steps of the PDI will be performed normally.

To continue with the PDI, press the bottom button.

ABORT — press both buttons to terminate the PDI. It is also necessary to use the ABORT command when a reparable defect is detected and the full PDI must be carried out again. The ABORT command is carried out automatically if the user does not respond to the prompt within two minutes.

The results of testing are recorded in the log.

During the test, no oxygen is added. The user is warned before the test begins. This must be confirmed for the test to take place.

The test result notifies the user if the unit is divisible, but does not influence the subsequent behavior of the apparatus; in particular, it does not block the functions necessary for undertaking a dive (in accordance with the Responsibility of the CCR Liberty User set forth in the introduction). Ignoring the conclusions of the pre-dive inspection is the diver's choice, for which he/she bears responsibility.

3.3.1 Internal testing of the control units

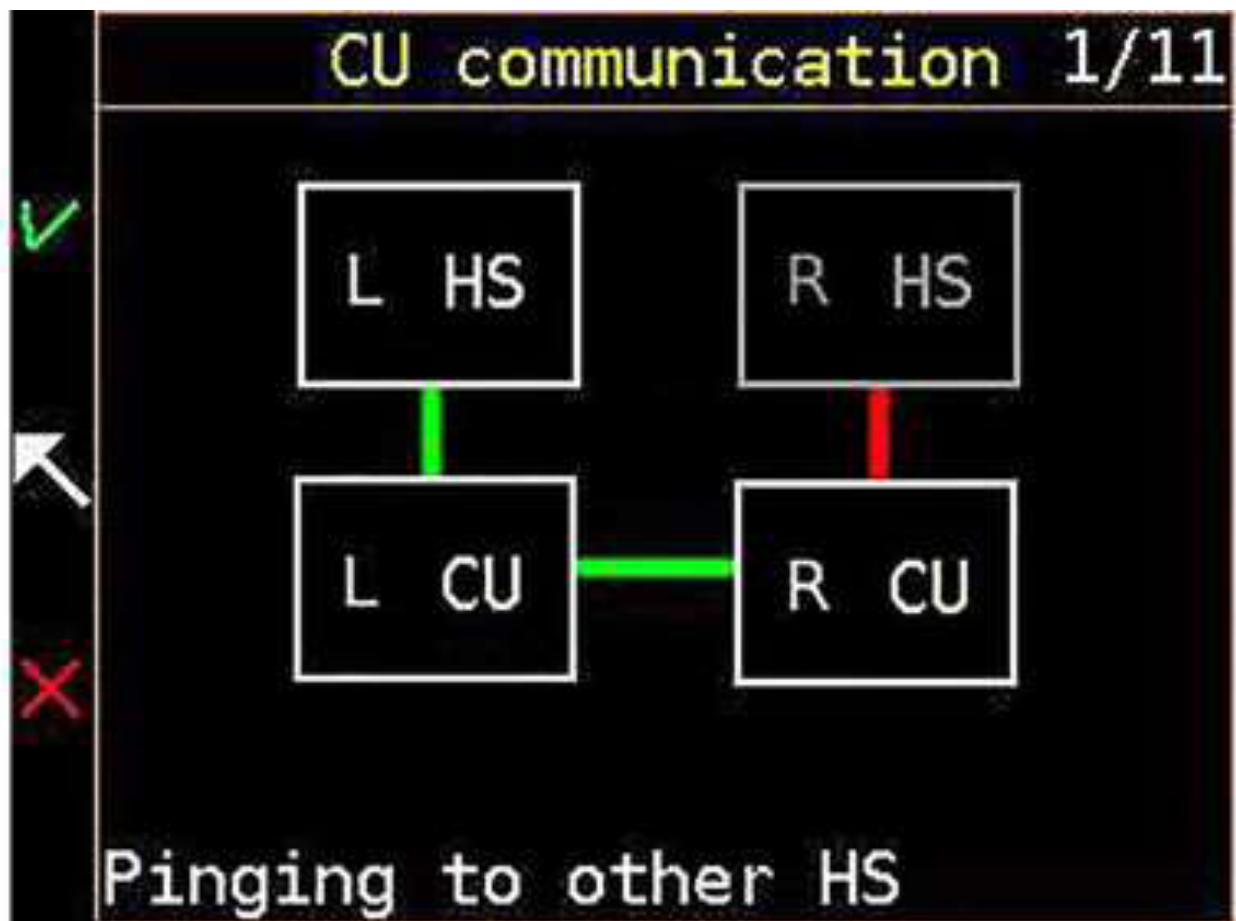

A communication test between the control units and the peripheral devices is automatically started at the beginning of the pre-dive inspection.

Testing is automatic. Confirmation by the user is required only in the event that the test result is negative.

If the individual elements of the system are connected correctly, a green line appears between them. If the connection has failed for some reason, or if part of the system is missing (for example, a disconnected handset), the line appears red.

3.3.2 Pressure sensor test

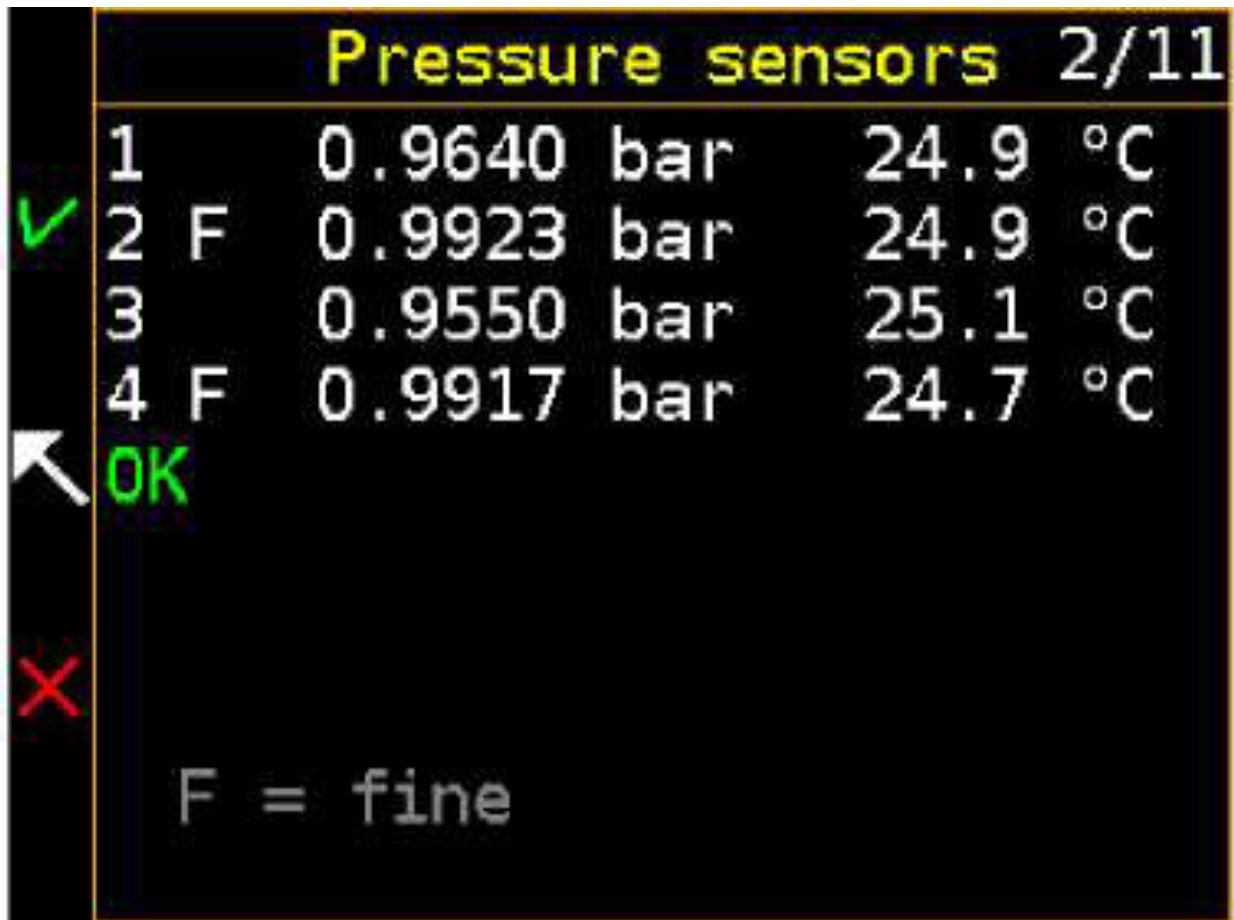

The screenshot shows a digital display titled "Pressure sensors 2/11". It lists four sensors with their respective pressure and temperature readings. A green checkmark is next to sensor 2, and a white arrow points to the word "OK" next to sensor 4. A red 'X' is visible on the left side of the display. At the bottom, it says "F = fine".

Sensor ID	Type	Pressure (bar)	Temperature (°C)	Status
1		0.9640	24.9	
2	F	0.9923	24.9	OK
3		0.9550	25.1	
4	F	0.9917	24.7	

F = fine

The system will display all pressure sensors and marked them with letters C or F.

C – coarse. A coarse pressure sensor that measures the pressure from the water level to a depth of 300 m.

F – fine. A fine pressure sensor that measures atmospheric pressure to depths up to 10 m.

The purpose of the pressure sensor test is to determine whether the pressure sensor values correspond to the actual pressure (altitude) and do not show any significant deviations from the expected pressure or from each other.

3.3.3 Comparison of oxygen sensors and their calibration

The screenshot shows a black display with yellow and white text. At the top, it says 'Oxygen sensors 3/11'. Below this, there are four rows of sensor data, each with a green checkmark to its left. The data is as follows:

Sensor ID	Voltage (mV)	ppO ₂ (bar)
1	10.15	0.20
2	9.71	0.21
3	10.19	0.20
4	10.41	0.20

Below the sensor data, there is a white arrow pointing to the text 'Fraction 20.3 %O₂'. Underneath that, the word 'Err' is written in red, followed by 'OCAL' in red. At the bottom, there is a red 'X' followed by the text 'Calibration Last: 41 days ago Recomended: 3 days'.

The current values of the individual sensors are shown on the display in millivolts (ppO₂ values are displayed in bars) using to the most recent calibration.

The purpose of the test is to verify that the oxygen sensors do not exhibit deviant voltage values, whether they are properly calibrated, and that the calibration is not too old.

During testing, keep in mind that sensors measure the actual value of ppO₂ in the loop. If testing is preceded by oxygen manipulation, this will be reflected in the sensor voltage.

Sensor check

- A sensor is Offline or reports Error.
- Online sensors are checked for minimum voltage; at least 5mV must be measured on air at sea level.
- The permitted tolerance between the largest and the smallest voltage is 5%.
- The calibration age must be less than the set value in the configuration.

3.3.4 Helium-sensor test

A functionality test of the He-concentration sensors is performed. The user is informed of the ongoing test on the HS display.



The purpose of the Helium-sensor test is to detect if the sensors are calibrated or if they show normal values. The picture shows a bad or missing calibration detected during the test. The test is automatic. Confirmation by the user is required only in the event that the test result is negative.

3.3.5 Battery testing

Battery		5/11
✓	Left	Right
	Ubat [V]: 3.885	3.840
	Charge: 60 %	49 %
←	Runtime: 7:00	5:00
	Status: Dischg	Dischg
✗	Is battery sufficient?	

Both batteries are stressed with an artificial load caused by an intentionally increased power consumption by the processors, connected solenoids (without using energy-efficient control), vibration motors, and the maximum brightness of the HS display. After completing the test, the status of both batteries (%) (including the estimated duration of the batteries in dive mode) are shown.

The user then decides whether he/she considers the batteries' estimated duration to be sufficient for the planned dive.

3.3.6 Solenoid testing

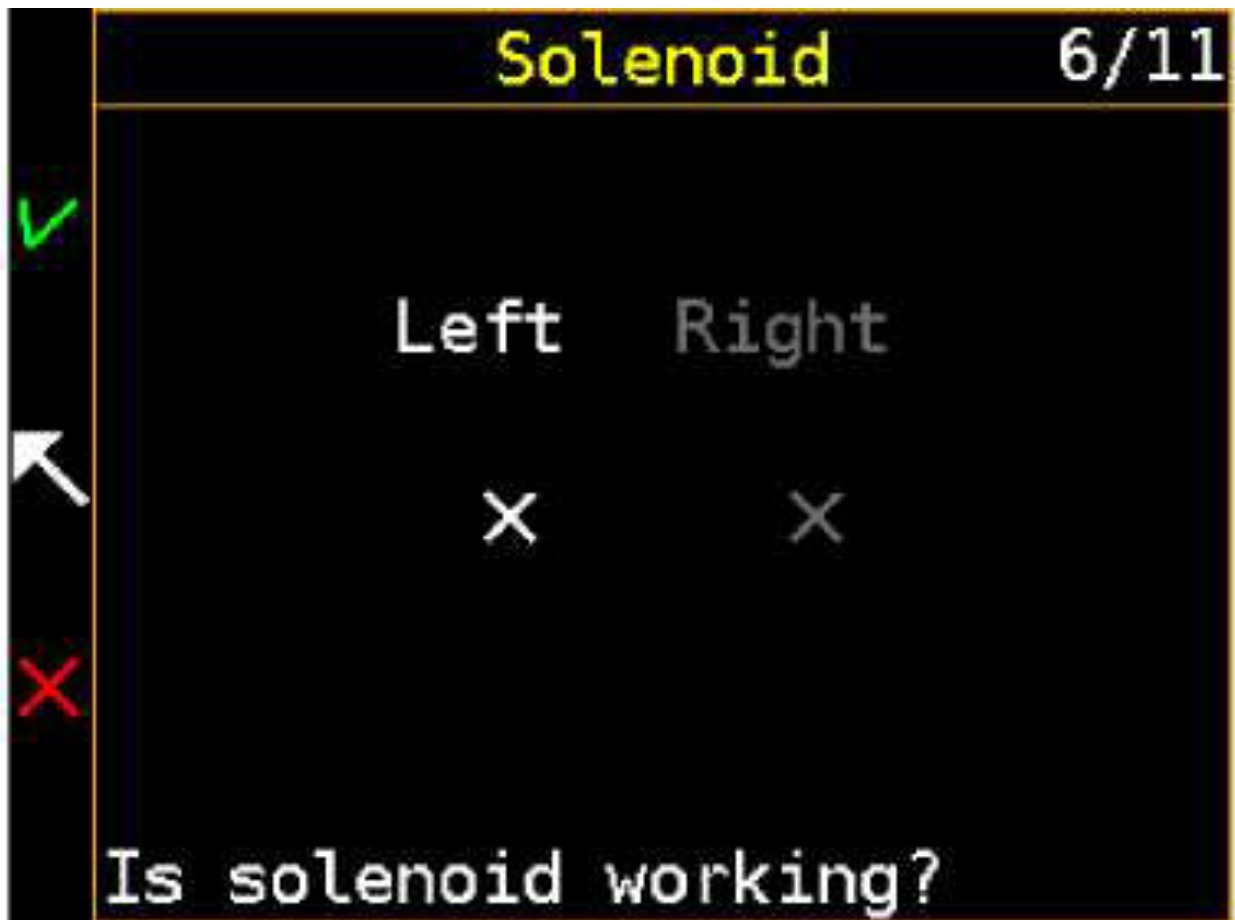

The left solenoid is repeatedly opened three times and closed in a two-seconds interval, with a 1:1 duty cycle. The expected activity of the solenoid is shown on the HS display. The right solenoid is subsequently tested in the same manner.

The test repeats cyclically if the user does not confirm the result or if automatic termination of the PDI does not occur due to the user's inactivity.

3.3.7 HUD inspection

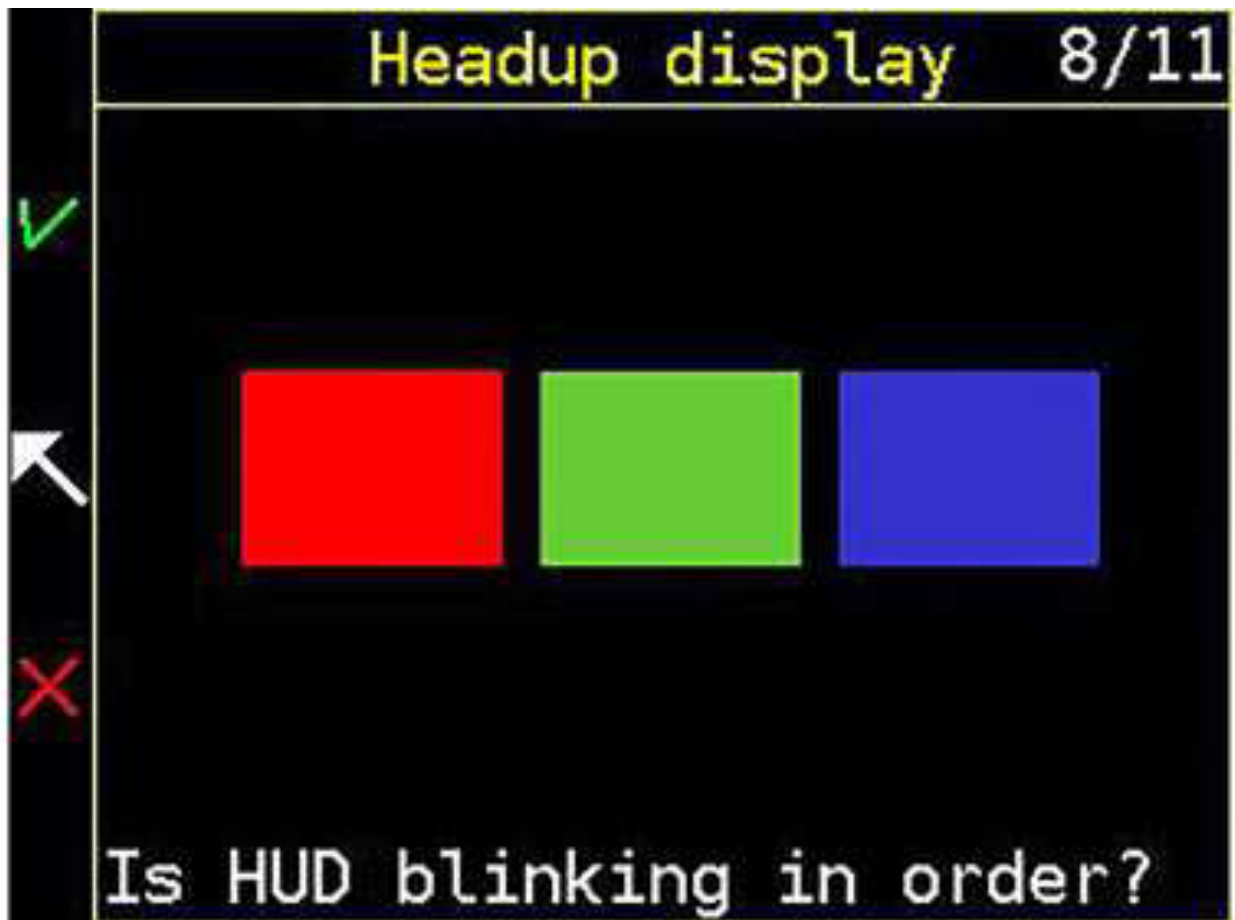

The diodes light up in blue, red, and green in three steps. At the same time, the HS displays which colors should light up on the HUD. Three different color combinations are displayed three times so that each of the three colors of the RGB spectrum are tested.

The test repeats cyclically if the user does not confirm the result or if automatic termination of the PDI does not occur due to the user's inactivity.

3.3.8 BD inspection

The buddy display successively lights up green at low, medium, and high intensities, then in red at low, medium and high intensities.

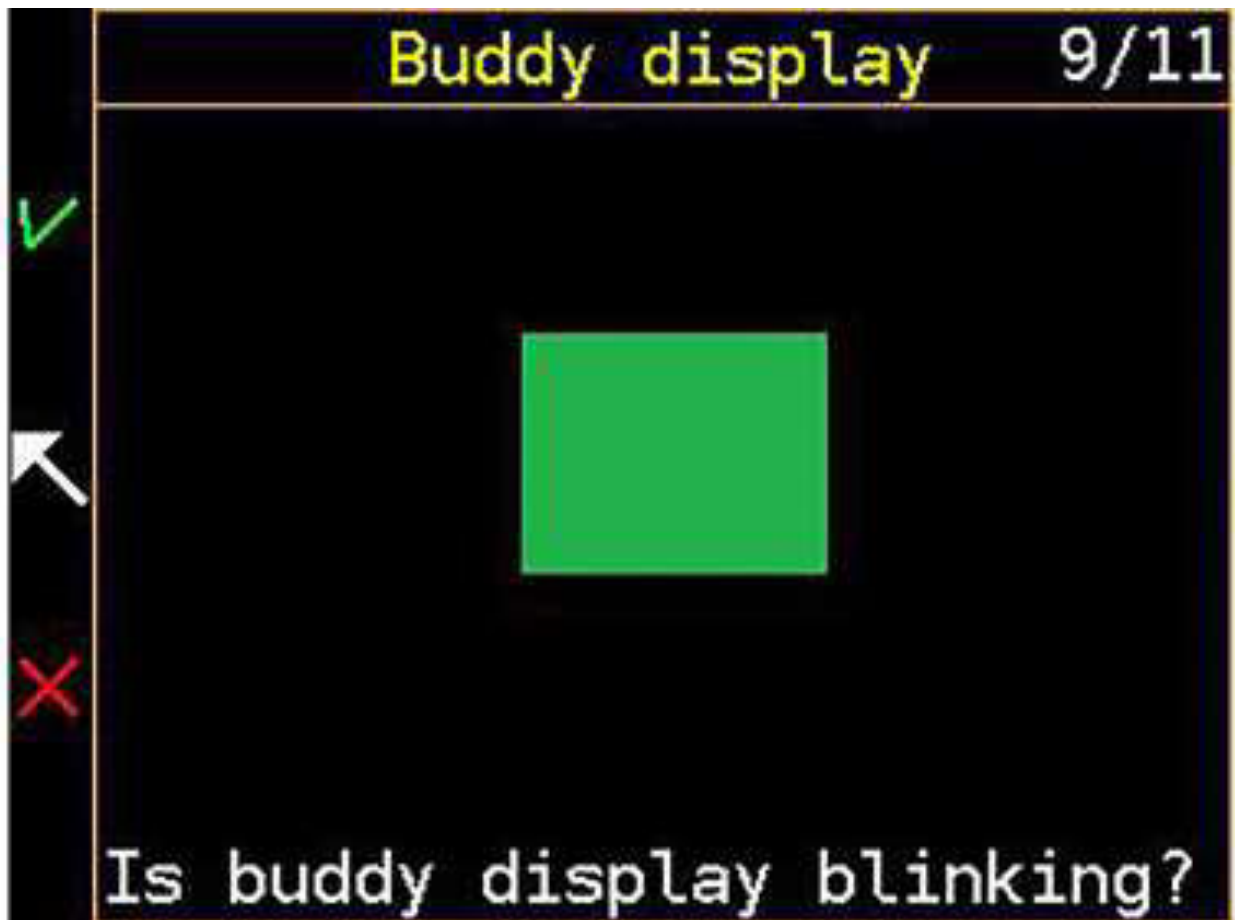

A symbol with the same color is at the same time displayed on the HS; intensity is indicated by the size of the symbol.

The test repeats cyclically if the user does not confirm the result or if automatic termination of the PDI does not occur due to the user's inactivity.

3.3.9 Negative pressure test

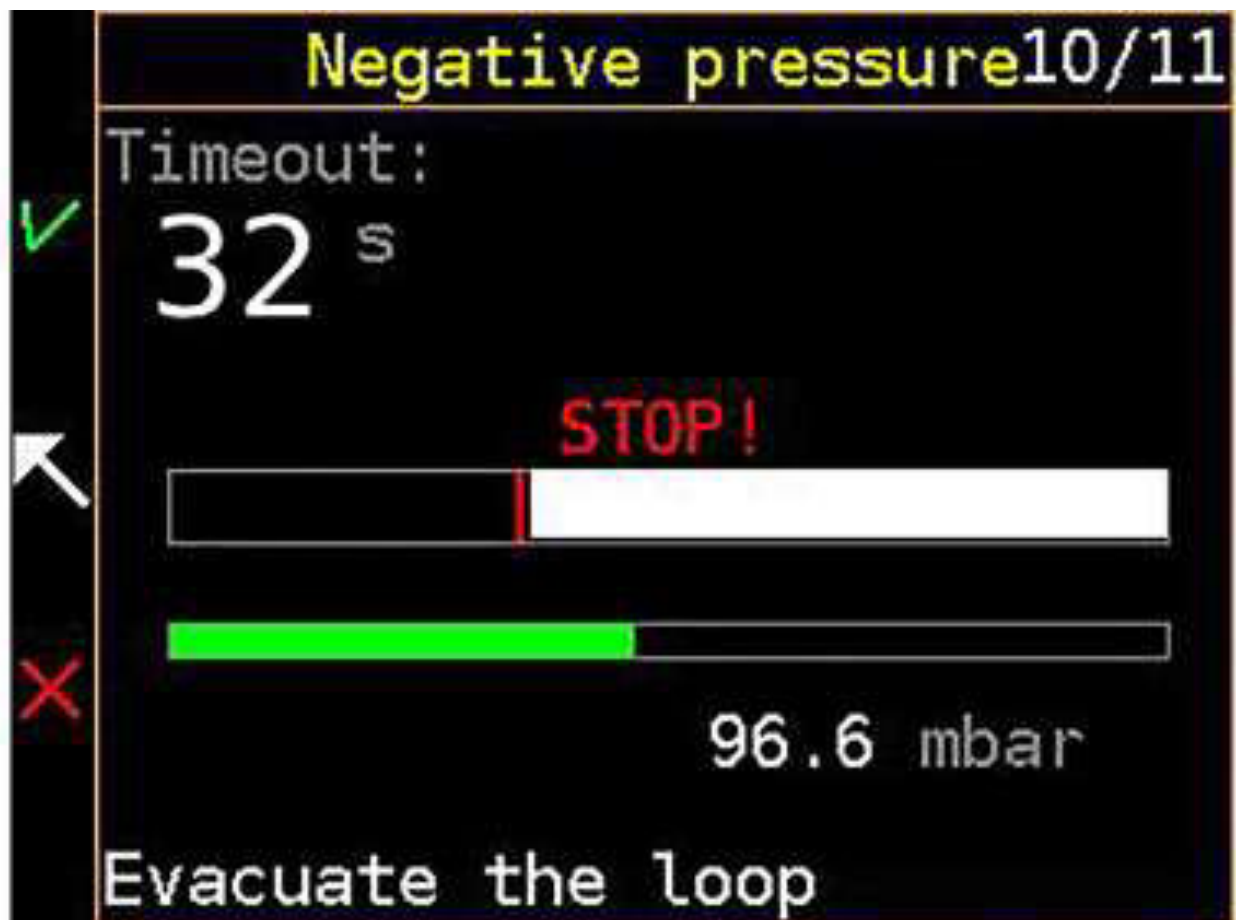

The purpose of this test is to detect possible leakage in the breathing loop, which appears when the pressure in the loop is lower the ambient pressure. The test is conducted immediately before diving, with a fully assembled rebreather.

Procedure:

1. Close the diluent and oxygen tank valves.
2. Open the DSV, and create sufficient negative pressure with your mouth according to the indication on the HS display. The negative pressure is indicated by a white bar graph. For sufficient leakage testing, it is advisable to develop such a negative pressure where the white bar graph will cross over the green field.
3. Close the DSV and cease all movement of the rebreather; in particular, do not move the bags and breathing hoses. After closing the mouthpiece, place the breathing hose loosely on the device. Movement of the breathing hoses and counterlungs causes pressure changes in the loop and distorts measurement results.
4. Wait 60 seconds; the countdown runs automatically on the display.
5. The test can be considered successful if the pressure loss after 60 seconds is less than 10 mbar (do not count the initial pressure change, as it is caused by the change

of hose length).

Final evaluation of the test and confirmation of the result are left at the user's discretion.

See also section 3.7.2 Detection of leaks.

Note: In spite of a positive result of a negative pressure test, leaks may occur during the dive. This is most often caused by a loose or punctured rubber mouthpiece.



3.3.10 Positive pressure test

The purpose of this test is to detect possible leaks in the breathing loop, which appears when the pressure in the loop is higher than the ambient pressure.

Procedure:

1. Close the oxygen tank valve and open the diluent tank valve.
2. Close the DSV, and close the overpressure valve.

3. With the manual diluent valve, create sufficient overpressure according to the indication on the HS display. It is also possible to do this using your mouth if you want to conserve gas in the diluent cylinder. If you want to set the device straight to the higher setpoint, pressurize the loop with oxygen.
4. Cease all movement of the rebreather; in particular, do not move the bags and breathing hoses.
5. Wait 60 seconds; the countdown runs automatically on the display.
5. The result is influenced by the opening of the over-pressure valve, which is set to a maximum of 35 mbar. If you notice a pressure leakage above this value, verify that it is only the over-pressure valve and that the leakage has no other source. The pressure should no longer fall below the set limit of the over-pressure valve. Final evaluation of the test and confirmation of the result are left at the user's discretion.

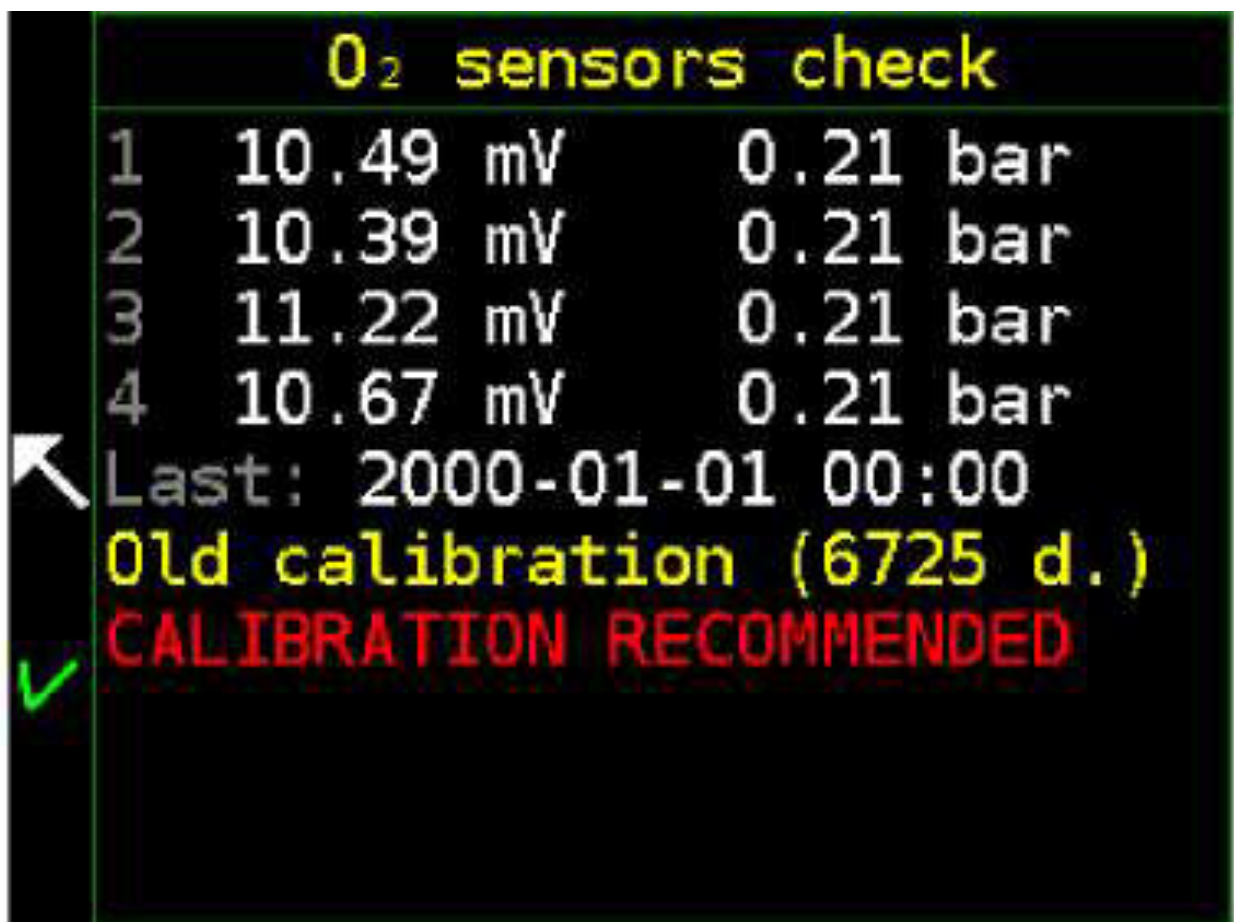

See also section 3.7.2 Detection of leaks

After finding and repairing the leaks, you must repeat all the pressure tests. For this you can use Menu / Pre-dive / Pressure tests, which skips all the sensor, battery, and

solenoid test, and starts the pressure tests right away.

3.3.11 IP Pressure

The last item of the pre-dive check is the intermediate pressure gas leak check. (It works only if pressure transmitters are connected).

1. The screen will display the initial pressure.
 2. Open the oxygen and diluent cylinders to pressurize the intermediate and high pressure compartments.
 3. Close the cylinder valves and observe any pressure drop as the display counts down. Any pressure drop indicates a leak in the intermediate or high pressure compartment. If this occurs, detect and correct the fault before diving.
 4. Open the valves fully again.
-

3.3.12 Pre-dive checklist

Upon entering Dive Mode, the unit automatically checks the oxygen sensors and their calibration. In the case of an old calibration or a sensor deviates of more than 10%, a warning will be issued along with recommendations for re-calibration. Follow the checklist. The diver is required to personally verify all the items listed.

Checklist step 1

Diluent valve open?
Diluent pressure ok?
ADV functioning?
Inflator functioning?
Diluent manual valve ok?
Overpressure test ok?
Diluent TMX 12/43 ok?



Checklist step 2

Oxygen valve open?
Oxygen pressure ok?
Oxygen manual valve ok?



Checklist step 3

Bailout pressure ok?
Bailout regulators ok?
Bailout TMX 15/55 ok?



Checklist step 4

Argon valve open?
Dry suite inflation ok?
Weights fastened?
OPV valves closed?
HUD ok?
Buddy display ok?
Torch ok?



Checklist step 5

Setpoints:

- descent: 0.40
- high: 1.40
- low: 1.20

Stack time: 1:48

L battery: 11 h

R battery: 11 h

Checklist step 6

Be careful!

Check reactions to pO_2 !

Check CO_2 regularly.

Go to bailout if not sure.

3.3.13 Prebreathe



Pre-breathing the unit has a major impact on the safety of the dive. We strongly recommend performing a pre-breath before and in between every individual dive. Pre-breathing is not related to the start of the scrubber's chemical reaction, but to **verify the important functions of the device before the dive, in particular, the ability of the device to maintain ppO₂ at the setpoint and the functionality of the sorbent.**



While the first function can be easily verified by observing oxygen sensors during breathing from the unit, testing the absorber functionality should only be performed under the conditions listed below, while also listening to your body's reactions. Even after a 5-minute pre-breathing from the unit, it is not guaranteed that a poorly filled or missing absorber has been detected.



Procedure:

1. Ensure that the setpoints are reached in the loop so that overinflating does not lead to excessive oxygen addition that distorts the test result.
2. Before starting the test, select a safe place to sit during its duration to avoid injury in case of loss of consciousness.
3. Put the mask on your face and keep it on throughout the entire test period to prevent the intake of ambient air through the nose, thereby compromising the accuracy of the test
4. Start breathing from the device, and start the countdown on the handset.
5. Monitor the partial pressure on the second handset and the behavior of all oxygen sensors.
5. Make sure you breathe comfortably, that your breathing does not stop, and that there are no feelings of breathlessness, nausea, headache, or other unusual conditions.
7. After finishing the test with a positive result, you can start the dive.

Warning: If you are pre-breathing in temperatures below freezing, under no circumstances should you stop breathing from the unit up until full submersion.

When you are not breathing from the unit, you are running the risk of letting your scrubber's interstitial space freeze, hindering its functionality

3.4 Diving

3.4.1 Breathing high oxygen content gases

The mixture in the CCR Liberty circuit usually contains oxygen at a much higher partial pressure compare to the air we breathe on the surface.

Acute (CNS) oxygen poisoning

Exposure to high oxygen partial pressure may, under certain circumstances, cause acute (CNS) oxygen poisoning. This can potentially cause the affected person to drown.

The so called "oxygen clock" is a percentage of consumption of CNS toxicity limit. Limit the maximum partial pressure and total exposure so that acute oxygen toxicity cannot occur, according to the following NOAA table.

NOAA oxygen exposure limits

ppO ₂ (bar)	Maximum Single Exposure (minutes)	Maximum per 24 hr (minutes)
1.60	45	150
1.55	83	165
1.50	120	180
1.45	135	180
1.40	150	180
1.35	165	195
1.30	180	210
1.25	195	225
1.20	210	240
1.10	240	270
1.00	300	300
0.90	360	360
0.80	450	450
0.70	570	570
0.60	720	720

Whole body oxygen toxicity

Long term exposure to oxygen partial pressure higher than 0.5 bar, common when using the CCR Liberty, leads to whole body (or pulmonary) oxygen poisoning. At exposures common to amateur technical diving, whole body toxicity symptoms are not significant. During rebreather diving, however, the diver is exposed to a relatively high partial pressure of oxygen throughout the dive, unlike with open circuit. Exceeding the whole body toxicity threshold is extremely dangerous.

For very long dives or a series of rebreather dives it is necessary to calculate with long-term exposure limits and to limit the overall exposure.

The main symptom of chronic toxicity is a temporary reduction in vital lung capacity. Another symptom may be nearsightedness (hyperoxic myopia). Symptoms may persist for several months.

When $ppO_2 \geq 1.4$ bar then the CNS toxicity limit is always shorter than the pulmonary toxicity limit.

For calculations related to chronic toxicity, use the REPEX method that you learned from your nitrox diving course. The CCR Liberty does not perform calculations associated with chronic oxygen toxicity.

3.4.2 Putting on the apparatus

After the pre-dive inspection, set the CCR Liberty on its stand on a hard surface – on the ground, a bench or table, or in a vehicle's cargo space. Properly secure the rebreather so that it cannot fall, for example, by having a partner hold it.

Procedure:

1. Flip the breathing bags and corrugated hoses with the DSV to the opposite side of the rebreather's body.
2. Position yourself under the shoulder straps. 101
3. Put on the shoulder straps, ideally with both arms at the same time.

4. Stand up on both feet. Due to the weight of the CCR Liberty, avoid rotating your spine, which could lead to injury. Before you stand up, carefully assume a kneeling position, and then stand up.
 5. Take the crotch strap up between your legs and pass the belt buckle through the eye of the crotch strap.
 5. Gently tighten the belt and fasten the belt buckle.
 7. Flip the breathing bags and corrugated hoses with the DSV to the front.
 3. Attach the breathing bags to the crotch strap V-straps with the buckles.
 9. Make sure that all of the straps are adequately tightened and are not twisted.
 3. Secure the handsets to your wrists. Ensure that the HS cables are wrapped around your arms.
 1. Ensure that the HUD is attached to the DSV and its cable is wrapped around the corrugated hose.
 2. Check the accessibility of the BCD inflator.
-

3.4.3 Using the DSV

The DSV must be closed at all times when it is not in your mouth. Close it before taking it out of your mouth; open it after putting it in your mouth, and clear the DSV before inhaling.

Opening the DSV when it is not in your mouth will cause an immediate loss of buoyancy and could possibly flood the breathing loop.



3.4.4 Monitoring of devices

Partial pressure of oxygen

You must know the concentration of oxygen (ppO₂) in the breathing loop at all times. Learn to use the HUD for continuous monitoring as it allows you to concentrate on other tasks.

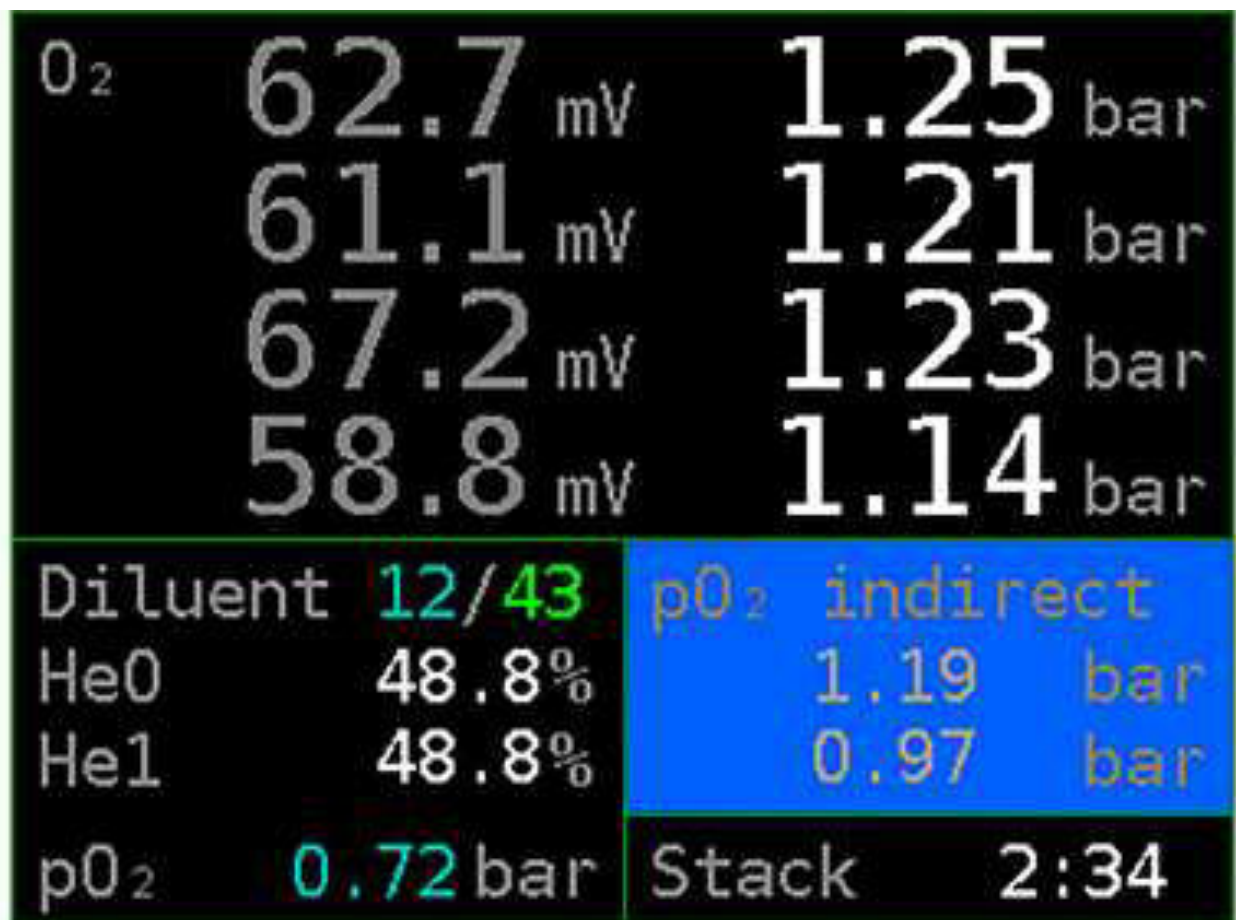

Always know your ppO_2 !

Check the partial pressure of oxygen on the handset display regularly as well. If the values from various sensors differ, check whether any of the sensors is coming to the end of its service life.

Pay extra attention to the ppO_2 reading when changing depth significantly.

Do not rely solely on the alarm indicating reduced partial pressure of oxygen.

Reduced partial pressure of oxygen is also signaled on the buddy display. Familiarize your diving partners with the BD signals so that they will be able to recognize in time that you need help.

For monitoring ppO_2 , it is not enough to monitor the average value of all sensors, which is highlighted by a larger font. All sensors must be monitored, either on the main display of the handset or on the screen containing all the sensors. In case one doubts the displayed measurement of one or more sensors, compare the indirect oxygen measurement values with helium sensors (only if the helium fraction in the

diluent is greater than 20% and helium measuring is enabled in the settings). These values can be found on the sensor voltage screen.

Another option is a diluent flush (correctly taught in the CCR Liberty Diver course) after which you compare the result with the value in the lower left corner on the sensor voltage screen. This gives the ppO_2 diluent at the current depth. The sensor, which after a diluent flush corresponds to the displayed value, can be considered valid. Pay attention if you are using a hypoxic diluent at a low depth.

The system can automatically disable one or two sensors. Always use your common sense, and make sure the discarded sensors are really the faulty ones and not the other way around.

Oxygen and diluent pressure

We recommend checking the pressure of oxygen and diluent approximately once every five minutes.

Compared to an open-circuit apparatus, the oxygen and diluent tanks have a small volume. Even a minor leak can cause rapid loss of pressure. Therefore, it is necessary to check the oxygen and diluent pressure gauges (SPGs) more frequently than when diving with an open circuit.

3.4.5 Switching to CCR mode

In surface mode, pull up the menu and switch to CCR mode.

Perform an inspection according to the displayed checklist.

3.4.6 Water entry

Do not enter the water without having performed a pre-dive inspection according to chapter 3.3 Pre-dive inspection!

We recommend breathing from the rebreather for at least three minutes right before entering the water in order to make certain that the scrubber and the rest of the apparatus are working properly.

In freezing weather, do not allow the scrubber to cool down after transferring the rebreather from a warm environment. Limit the rebreather's exposure to freezing air. If necessary, keep the sorbent warm by breathing from the rebreather.

We recommend gradually entering the water and submerge the rebreather slowly.

If it is necessary to jump into the water, use the "giant stride" method, whereby your legs and buttocks impact the water first, thus protecting the breathing bags and corrugated hoses from direct impact. When entering the water in this manner, have the DSV in your mouth; have it closed at the moment of entry. Sudden entry into the water must be supervised by a person qualified to provide assistance in the event that problems arise.

Perform a bubble check after entering the water. Due to the small volume of the oxygen and diluent tanks, minor leaks in the high-pressure and low-pressure parts, can lead to a rapid decline of pressure in the tanks.

3.4.7 Submersion

During submersion, use the compensator (BCD) to control buoyancy.

Choose an appropriate amount of ballast with respect to any possible change in weight during a dive. Do not overload yourself to facilitate submersion. Unlike in open-circuit diving, weight reduction due to consumption of gases is minimal. The possible use of the open-circuit bailout apparatus has a more significant impact on weight reduction. Determining of the correct amount of ballast is one of the skills that you will learn in the CCR Liberty course.

3.4.8 In-water check

Verify the ppO_2 control system and adjust buoyancy.

Perform a bubble check with your diving partner. Scan all parts of the breathing loop in the direction of the gas flow. Rotate horizontally using the "helicopter turn".

Check your bailout source. Take a few breaths from the bailout bottle to see if the regulator is easily and quickly available and functional. Check the pressure in the bailout cylinder.

3.4.9 Descent

During the descent, the ADV adds diluent to the breathing loop; you can also add diluent manually. Diluent is added to the inhalation bag. During a rapid descent, the mixture delivered to the DSV is practically identical to the diluent.

If you use diluent with a low oxygen content (e.g. when starting a descent to a great depth), it is necessary to significantly limit the descent rate. Continue this until you reach a depth where the ppO_2 in the diluent exceeds 0.2 bar. It is also possible to isolate the ADV and administer the diluent manually for maximum control over the injected hypoxic diluent.

Do not descend rapidly in order to reach the depth at which the mixture is breathable. Low partial pressure of oxygen in the loop leads to a significantly faster loss of consciousness than if you descend while holding your breath. Do not take this risk.

Upon completion of the descent, it is possible to isolate the ADV to accurately maintain the optimum loop volume.

3.4.10 Controlling buoyancy and trim

When diving with a rebreather, buoyancy cannot be controlled by breathing as in open-circuit diving. Since you are breathing within a closed loop, there is no effect on the overall buoyancy.

Buoyancy corrections, however minor, is controlled with the compensator.

For a very small, increase of buoyancy temporarily (e.g. when swimming over an obstacle), you can add a small amount of diluent into the breathing loop instead of using the compensator. Though this method is convenient, it also leads to a greater consumption of oxygen and diluent. Remember: swimming around an obstacle is better than swimming over it.

Keep balance corrections to a minimum by using other sources of buoyancy, such as a dry suit. The increased difficulty of controlling several points of buoyancy can overload the diver with tasks.

The optimum trim of the diver is horizontal, even when descending and ascending. During the course on diving with the CCR Liberty, you will find the optimum ballast position. Do not use a weight belt.

When training to achieve the correct balance and trim, try to remain motionless and not change depth or body position for several tens of seconds.

A buoyancy backup system is always needed when diving. For example, this can be a dry suit, disposable ballast, a lift bag.

3.4.11 Mask clearing

When diving with a rebreather, a significant portion of the mixture consumed during a dive can be lost when clearing the mask. Therefore, keep mask clearing to a minimum.

3.4.12 Increased physical exertion

The CCR Liberty adds oxygen to the breathing loop as needed. Unlike with some mechanical rebreathers, increased physical exertion does not lead to a reduction of the partial pressure of oxygen.

In the case of longer physical exertion, check the pressure in the oxygen tank frequently.

Take increased physical exertion into account for your decompression planning.

Increased effort also causes greater CO₂ production. In addition to shortening the life of the scrubber, increased CO₂ production (along with reduced ventilation due to gas density) has a significant effect on the increase in arterial CO₂. This phenomenon causes a greater susceptibility to oxygen toxicity and nitrogen narcosis. There is also the risk of acute hypercapnia. Avoid increased strain at depth.

3.4.13 Ascent

Under normal conditions (i.e. when ascending at a rate less than 15 m/min., with a minimum setpoint 0.8 bar) and a normal functioning apparatus, a decline in oxygen partial pressure (ppO₂) below the limit of 0.16 bar does not occur.

If an inadvertent rapid ascent occurs in shallow depths, pay great attention to the ppO₂. It is possible that a short-term decline will happen, but this will be automatically corrected with two to three inhalations.

Before starting an ascent, check to ensure that the oxygen tank valve is fully open.

During the ascent, expansion of the breathing mixture in the circuit occurs due to the reduction of ambient pressure. It is necessary to expel the excess breathing mixture. The overpressure valve on the exhalation (right) counterlung is used for this purpose. Open the overpressure valve completely. Some divers consider it more convenient to expel excess breathing mixture via the nose through the mask. Do not expel excess gas via the mouth as doing so increases the risk of water leaking into the breathing circuit via the mouthpiece.

3.5 Post-dive procedures

3.5.1 Immediately after surfacing

Close the DSV, put the rebreather in a suitable place, close the tank valves and switch off the control units.

If a stable, firm, and level surface is available, set the rebreather up on its stand and take measures to prevent it from falling.

If you are in the field where it is not possible to place the rebreather on its stand, lay it down.

When handling the rebreather, focus particular attention on protecting the corrugated hoses against damage.

As a general rule, it is necessary to dry out the water trap after every dive or at least at the end of the diving day. Detach the head, remove the scrubber cartridge, remove the water trap, and dry it with a paper towel. Use another paper towel, to dry the exterior surface of the cartridge.

The head should be left to dry to ensure proper functionality of the oxygen and helium sensors. Helium sensors are sensitive to moisture and condensation. Since moisture can condense directly inside the sensor, it is vital to dry out your head properly after diving.

This is important to ensure a long lifetime and functionality of your sensors.

In areas or periods with increased humidity, we strongly recommend using the DIVESOFT Head drying fan.

3.5.2 CO₂ scrubber maintenance

If the sorbent capacity is sufficient (with reserve for the next planned dive and not disinfecting the rebreather until the next dive), it is possible to reinsert the scrubber cartridge into the canister and leave it in the rebreather. You can leave the scrubber canister opened for a maximum of 24 hours if stored in a dry place. Mount the dry head and close the breathing loop openings for longer storage. We recommend using

the "DIVESOFT scrubber cover with stickers". It is advisable to write the date of the first filling and the times of the individual dives on which the scrubber was used. Change the label after replacing the sorbent. Do not store used and sealed scrubber for more than 30 days after its first use.

3.5.3 Cleaning and disinfection

When in use, the rebreather's breathing loop is colonized by microorganisms from the diver's respiratory tract and from the external environment. The purpose of regular cleaning and disinfection is to prevent the multiplication of these microbes to an extent that would pose a hazard to the user and to prevent the transmission of infection between various users.

No more than a week may pass from the first dive after disinfection until the next disinfection if the CCR Liberty is stored in a cool place. When storing the rebreather at a temperature higher than 25 °C, this interval decreases to four days; the weekly interval can be maintained only for the scrubber cartridge. It does not matter how many dives you undertake during the stated period.

Disinfection is always necessary before changing users of the CCR Liberty. Never lend or borrow a rebreather that has not been disinfected! Transmission of infection can happen with a single inhalation. An infected user will not necessarily have any symptoms of infection.

Begin cleaning by rinsing the assembled rebreather with clean fresh water.

Disassemble the rebreather into its individual parts.

Procedure:

1. remove the ballast.
2. unscrew and detach the oxygen and diluent tanks, insert watertight stoppers in the regulator inlets.
3. remove the HUD from the DSV.
4. remove the breathing bags with corrugated hoses from the head.

5. remove the ADV, manual valves, and overpressure valve from the breathing bags.
5. detach the breathing bags from the harness.
7. remove the head with the attached handsets and HUD.
3. remove the CO₂ scrubber from the cartridge and dispose of it safely.
9. remove the scrubber canister from the backplate, and remove the water trap.
Put the head with the control units in a clean, cool, and dry place.

Prepare the antiseptic solution in a suitable container, free of mechanical and chemical impurities. For example, a bathtub, mortar tub, or large Tupperware container is suitable for disinfection.

For ordinary disinfection, use a 0.5% concentrated Divesoft antiseptic. Follow the instructions when working with the antiseptic agent.

Rinse with clean fresh water and place the tube, water trap, corrugated hose assembly with an open DSV, breathing bags, and CO₂ filter in the tub. Manipulate the corrugated hose assembly and the DSV to expel air so that the antiseptic solution fills the entire space (this necessary skill is taught in the CCR Liberty training course). Completely fill the breathing bags with the antiseptic solution.

If you notice mold growth, it is necessary to perform a thorough disinfection and surface cleaning. Most surfaces can be wiped with an antiseptic soaked rag. Use a bottle or tube brush to clean the inner surfaces of the corrugated hoses.

Leave the parts in the antiseptic solution for one hour. Remove the parts when complete and rinse with clean fresh water, allowing them to dry afterwards. Do not dry the parts in direct sunlight.

When more intensive disinfection is required, use a more concentrated solution (maximum 2%) or leave the parts in the antiseptic solution for a longer time (maximum four hours).

Instead of Divesoft disinfection, one can use a different antiseptic agent based with quaternary ammonium salts that is compatible with the materials from which the CCR Liberty is made. The CCR Liberty's manufacturer does not guarantee the

compatibility of antiseptic agents other than Divesoft disinfectant. In any case do not use chlorine-based agents.

In normal circumstances, the head, ADV, manual bypass valves, and overpressure valve do not need to be disinfected.

If a more thorough disinfection is required, the oxygen sensors can be removed from the head, and the remaining parts can be washed with antiseptic solution. The ADV, manual bypass valves, and overpressure valve can be disinfected by submerging them in the antiseptic solution.

The antiseptic solution is highly toxic to aquatic organisms. Dispose of it in an environmentally friendly manner.

3.5.4 Battery care

Prevent complete discharging of the batteries. If possible, charge the batteries after each day of diving.

3.5.5 Dive log download

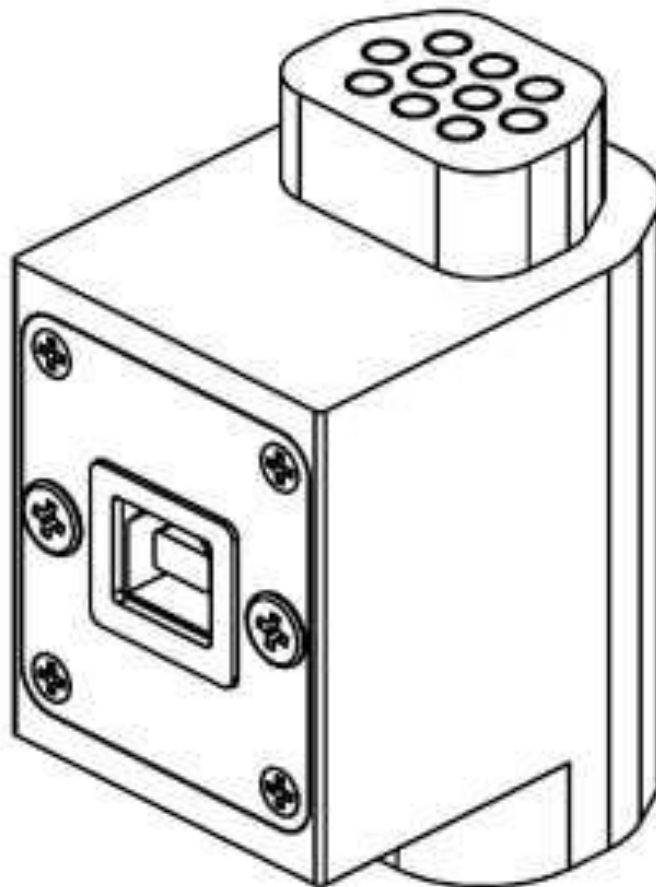

After disconnecting the handset and attaching a multipurpose USB connector to the handset connector on the head (without the connected handset), the CCR Liberty's dive-record memory is accessible via the USB interface in mass storage mode. This means that for the computer to which the USB cable is connected, it appears as an ordinary flash drive with a read-only restriction. Records of individual dives are stored as separate files in the divelog folder.

The control unit (CU) offers a micro DC card insert. Such a card is installed by the manufacturer, and a separate dive log (which is not dependent on the CU's memory), is stored on it. The card's capacity is sufficient for storing detailed logs throughout the apparatus's service life, though the diver can delete logs from the card whenever they want. The card is generally accessed in the same manner as accessing a mass storage device via a USB cable, though in the case of damage to the CU, the micro SD card can be removed from the connector on the control-unit board and the dive log can be read using an ordinary reader.

Diver may upload the Liberty dive logs into the cloud at wetnotes.com.

3.5.6 Long-term storage

Before storing the rebreather for a period longer than one week, proceed according to section 3.5.3 Cleaning and disinfection.

If the CCR Liberty is stored in a dry and clean environment, do not connect the corrugated- hose assembly with the DSV to the head or to the breathing bags, and store the rebreather open. Dust occurs almost everywhere and is inevitable. Limit the accumulation of dust by, for example, covering the unit with a washed bed sheet. Store the detached corrugated hose assembly in a suitable container that will allow complete drying.

If you store the CCR Liberty in an environment with a lower degree of cleanliness, such as a home with pets, store it assembled and closed (without sorbent).

Before putting the closed rebreather in storage, all parts must be thoroughly dried, including all creases in the corrugated hoses and the interior surface of the bags.

Charge the batteries at least once every six months.

If, after storing the unit for more than a month, you find that moisture persists inside the apparatus, or you can smell mustiness or mold from the corrugated hoses, it is necessary to disinfect the apparatus again.

When storing the rebreather, make sure that no rubber parts (hoses, cables) are pinched or compressed.

Ensure that the rebreather is securely fastened, and no other objects are leaning against it.

3.6 Emergency procedures

Prevent the occurrence of emergency situations through high-quality training. Do not exceed the limits of your diving qualifications. Carefully adhere to the prescribed procedures before, during, and after every dive. In the event that prior to a dive you

discover a problem associated with the rebreather, and you are not able to resolve it, do not dive with the rebreather, regardless of the severity of the problem.

3.6.1 Emergency ascent (bailout)

For safety purposes, it is necessary to carry a bailout apparatus whenever diving on a rebreather. A common type of backup device is a standard stage bottle.

If, during a dive, a malfunction occurs in the CCR Liberty that you are not able to resolve or precisely identify, or if you have a suspicion that something is wrong with the rebreather, switch to the bailout apparatus:

1. place the bailout breathing apparatus in the standby position,
2. exhale into the circuit and close the DSV, but hold a sufficient amount of gas in your lungs for removing water from the mouthpiece of the bailout apparatus,
3. Perform the standard procedure associated with beginning to breath of the bailout apparatus, e.g. for stage tanks, check to be sure that you are breathing from the correct stage tank.

If you subsequently resolve the rebreather malfunction or if you determine that the cause of the problem is outside the rebreather, you can resume breathing off the rebreather.

After switching to bailout OC mode, the safety level is automatically set using the bailout gradient factors (BoGF). It is possible to switch between the standard and bailout GF sets in the menu without affecting the mode in which the CCR Liberty is operating.

Knowledge and skills related to stage bottle use is a necessary requirement for anyone interested in diving on the CCR Liberty. In a CCR Liberty diving course accredited by the manufacturer, the use of stage bottles for backup purposes is thoroughly practiced.

3.6.2 Oxygen-source malfunction

Low pressure in the oxygen tank

In this case, it is necessary to terminate the dive.

It is necessary to switch to the bailout breathing apparatus no later than when the partial pressure of oxygen in the circuit falls below 0.3 bar.

If this situation arises due to a lack of thoroughness when preparing for the dive or due to failing to regularly check the pressure during the dive, please consider whether diving with a rebreather represents too great of a risk for you.

Solenoids have stopped delivering oxygen

If the partial pressure falls significantly below the setpoint, but there is still sufficient pressure in the oxygen tank, use the manual bypass valve to add oxygen.

Add oxygen gradually by performing short presses. Breathe regularly. Oxygen will be delivered to the exhalation bag. It takes several inhalations before the oxygen in the scrubber blends with the breathing mixture and reaches the sensors on the inhalation side.

If the situation persists, control the delivery of oxygen manually. In a stabilized state (a low level of exertion at a fixed depth), it is necessary to add oxygen approximately once or twice per minute.

This malfunction does not pose an immediate threat to the diver. However, do not continue in your descent or penetration. Start your ascent or return.

Manual O₂ bypass valve free-flow

Disconnect the quick-release. Disengaging the quick-release connector causes a disruption of the oxygen delivery via the manual bypass valve.

This malfunction does not pose an immediate threat to the diver. However, do not continue in your descent or penetration. Start your ascent or return.

Manual bypass valve does not function, oxygen is not added after pressing

This malfunction does not pose an immediate threat to the diver. However, do not continue in your descent or penetration. Start your ascent or return.

Oxygen delivery does not function by means of either the solenoids or manual bypass valve

In this case, it is necessary to terminate the dive.

It is necessary to switch to the bailout breathing apparatus no later than when the partial pressure of oxygen in the circuit falls below 0.3 bar.

3.6.3 Diluent-source malfunction

Low pressure in the diluent tank

In this case, it is necessary to terminate the dive. During the ascent, the diluent in the circuit expands and thus replenishes its volume in the circuit. If possible, do not increase depth during your return.

As long as the volume of diluent in the circuit is sufficient, it is possible to breathe from the rebreather. If it is not sufficient, it is necessary to switch to the bailout breathing apparatus.

Bear in mind that in this case it is not possible to perform the standard procedure for high ppO_2 (flushing out the loop, adding diluent) and that such a situation can be resolved only by immediately switching to the bailout breathing apparatus, which you should have in standby position.

ADV free-flow

Close the ADV by sliding the collar. This causes a disruption of the diluent delivery via the ADV.

This malfunction does not pose an immediate threat to the user. The dive can continue with manual addition of diluent to the circuit.

Manual bypass valve free-flow

Disconnect the quick-release. Disengaging the quick-release connector causes a disruption of the diluent delivery via the MBV.

This malfunction does not pose an immediate threat to the user. The dive can continue with automatic delivery of diluent into the circuit using the ADV. Manual delivery of diluent can be accomplished by pressing the ADV.

Manual bypass valve does not function, diluent is not added after pressing

This malfunction does not pose an immediate threat to the user. The dive can continue with automatic delivery of diluent into the circuit using the ADV. Manual delivery of diluent can be accomplished by pressing the ADV.

Neither the ADV nor the manual bypass valve functions

If the diluent pressure gauge indicates sufficient pressure, a malfunction in the first stage of the diluent regulator has likely occurred, and it is no longer possible to add diluent to the circuit.

In this case, it is necessary to terminate the dive. During the ascent, the diluent in the circuit expands and thus replenishes its volume in the circuit. If possible, do not increase depth during your return.

If the volume of diluent in the circuit is sufficient, it is possible to breathe from the rebreather. If it is not sufficient, it is necessary to switch to the bailout breathing apparatus.

Bear in mind that in this case it is not possible to perform the standard procedure for high ppO_2 (flushing out the loop, adding diluent) and that such a situation can be resolved only by immediately switching to the bailout breathing apparatus, which you should have in standby position.

3.6.4 Scrubber malfunction

If you feel the need to breathe more rapidly (ruling out your exertion level), it is possible that a higher carbon dioxide concentration is present in the circuit due to a scrubber malfunction. Other symptoms of a CO₂ hit include nausea, headache, confusion.

On the contrary, another possible cause of similar symptoms is psychosomatic hyperventilation and reduced content of carbon dioxide in the blood and other bodily tissues. This usually occurs due to increased mental stress, such as when the diver is confronted with task overloading.

If the symptoms are severe, immediately switch to the bailout breathing apparatus, as there is a risk of a loss of consciousness. As soon as possible, take several slow, deep breaths from the backup apparatus. Of course, you should never allow such a situation to progress to the stage of severe symptoms.

If you experience discomfort when breathing but the symptoms are not severe enough to pose a risk of unconsciousness, test the concentration of carbon dioxide in your blood. Stay where you are without moving; do not in any case change depth significantly. Try to hold your breath for ten seconds.

If you are unable to hold your breath or it is extremely difficult to do so, it is apparent that the scrubber is not functioning properly (premature depletion of the sorbent, occurrence of channels in the sorbent by which air circumvents the scrubber) or there is a mechanical malfunction that has caused air to not pass through or to only partially pass through the scrubber (malfunction of the directional valve on the mouthpiece, joining of the inhalation and exhalation sides outside the scrubber). Switch to bailout and terminate the dive.

If holding your breath does not cause problems, the scrubber is working properly. Over the next several minutes, limit all other activity and concentrate on slow, steady breathing.

3.6.5 Inadvertent release of the mouthpiece

When the mouthpiece falls out of the diver's mouth, the DSV has a tendency to float. However, its connection to the breathing bag prevents the mouthpiece from floating beyond the diver's reach.

If the mouthpiece falls out, immediately place it back in your mouth. If the mouthpiece is returned quick enough, no significant amount of water will have entered the breathing loop.

If this problem is not solved quickly, then the loop would flood. In this case, proceed according to the following section 3.6.6 Flooding.

There may be a strap (bungee cord) holding the DSV, which prevents the mouthpiece from accidentally falling out. Adjust the length of the bungee by shifting the knots.

3.6.6 Flooding

The probability of significantly flooding the breathing circuit is very low. After carefully assembling the apparatus and performing the prescribed pre-dive procedures, flooding can be ruled out unless there is a major disruption of the breathing loop's integrity due to mechanical damage. In the event of significant flooding, it is necessary to immediately switch to the bailout breathing apparatus and to use the compensator (BCD) to prevent loss of buoyancy.

Do not inhale if the mixture from the rebreather's DSV contains fluid. In extreme cases, this could contain a so-called caustic cocktail (i.e. a caustic mixture with dissolved lye from the sorbent).

A smaller amount of water can enter the circuit through the opened DSV when the mouthpiece falls out of the diver's mouth. In such a case, water gets into the exhalation bag. Though this does not present an immediate danger, it is advisable to expel the water from the exhalation bag with the overpressure valve as soon as possible. Open the overpressure valve completely and deflate the buoyancy compensator. In order to avoid a significant change in buoyancy. Add diluent to the

circuit with the manual bypass valve. Assume a position that brings the overpressure valve to the lowest point of the exhalation bag. Expel the water from the bag by pressing on the bag with your hand.

3.6.7 Loss of buoyancy

The compensator (i.e. buoyancy control device or BCD) is the basic tool for controlling buoyancy. If the compensator is not functional, use other means of attaining buoyancy.

If the compensator's lift capacity does not suffice or if it fails to fill (whether that be with the power inflator or orally), use your dry suit to attain buoyancy. The CCR Liberty user must have sufficient knowledge and skill to safely use a dry suit as a backup source of buoyancy.

If it is not possible to attain sufficient buoyancy by using the compensator and dry suit and if, there is no other appropriate option, jettison the ballast. If it is not necessary to completely jettison the ballast, try to attain buoyancy by first removing the ballast on the left side and then, if necessary, on the right side. Jettisoning the ballast on the left side helps to bring the dry-suit release valve and the compensator's inflator in a better position for deflation.

Jettisoning ballast is a skill that, in addition to agility and mobility, requires training under the supervision of an instructor in a CCR Liberty diving course.

3.6.8 Rescue on the surface

When assisting an injured CCR Liberty user on the surface, it is possible to increase buoyancy by jettisoning the ballast.

Even if the diver's life is in serious danger, and it would be necessary to remove all equipment during the rescue, buoyancy should be ensured by closing the DSV, inflating the compensator wings, and jettisoning the ballast. Complete removal of

the CCR Liberty and any other equipment attached to the harness can be time consuming. Sufficient buoyancy provided by the CCR Liberty can aid in the rescue process.

3.6.9 Malfunction of oxygen-concentration measuring

If the chemical oxygen sensors are not functional (excluded, disabled, error or offline state, see section 2.4.8 Faulty sensors) and a trimix is used as the diluent and the helium sensors are functional, then the CCR Liberty can be switched to indirectly determine the ppO_2 by measuring the helium content. See section 1.9.3 Measurement of He content.

Consider this as an emergency procedure only when it is not possible to proceed according to section 3.6.1 Emergency ascent (bailout).

3.7 Maintenance

Maintenance operations, including necessary technical information, are described in the maintenance manual. In the user manual, only basic maintenance operations that every CCR Liberty user should master are described.

Use only oxygen-compatible lubricant for the maintenance of parts that come into contact with oxygen under pressure.

3.7.1 Tools and replacement parts

Your toolbox for resolving problems in the field should contain:

- Surgical gloves
- Roll of paper towels
- PE bag for storing the scrubber cartridge
- DSV mushroom valves (2 pcs)
- Mouthpiece

- Tightening straps
 - Oxygen-compatible lubricant
 - 2.5 mm and 3 mm hex keys
 - #1 Phillips screwdriver
 - Tool for removing O-rings (O-ring pick, plectrum, bamboo toothpick)
 - Adjustable wrench
 - Duct tape
 - Permanent waterproof marker for writing on duct tape
 - Set of O-rings
-

3.7.2 Detection of leaks

If the source of a leak is not apparent, we recommend pressuring the unit to find the leak.

Leaks can generally be found by submerging a part or the entire rebreather in water while exerting pressure in the breathing loop. It is also possible to find leaks by applying a soapy solution on a certain area.

After eliminating the problem, negative and positive pressure tests must be repeated.

3.7.3 Regular service inspection

The CCR Liberty requires yearly service inspections (maximum 12 months) or after 150 hours of usage, whichever occurs first.

Service inspections must be performed by a service technician certified by Liberty Systems or performed by the manufacturer. The replacement of components and the inspection process are determined by the manufacturer's guidelines at the time of inspection.

3.7.4 Long-term maintenance

Oxygen sensors

When the oxygen sensors are calibrated, their degree of wear is checked. Of course, sensors can suddenly reach the end of their service life even during a dive, especially in an environment with a high partial pressure of oxygen. Therefore, we recommend replacing the sensors no later than one year after putting them into operation or 18 months max after their date of manufacture.

However, despite good handling, the sensors may, exhibit deviations or limitations even during their recommended life. For this reason, we recommend using the DIVESOFT Oxygen sensor tester kit regularly to test the linearity of the sensors. It is the only accurate and safe way to detect a faulty or limited sensor.

It is not necessary to discard replaced sensors. Even though a sensor's degree of wear prevents it from reliably measuring higher partial pressures of oxygen in the rebreather, it is often useful for measuring lower partial pressures of oxygen when preparing mixtures.

Hoses

If any hose shows signs of excessive wear or if damage is detected during a bubble check (see chapter 3.4.8 In-water check), replace it. Hoses should be replaced during annual inspection from normal wear and tear.

The service life of the hoses is five years max from the time they were first used and seven years max from their production date.

Straps

The harness straps are highly durable. A strap that has been damaged on the edge should only be replaced if it was cut more than one-third of its width.

Straps are generally replaced for aesthetic reasons. You can order a replacement when ordering a regular service inspection.

3.7.5 Firmware update

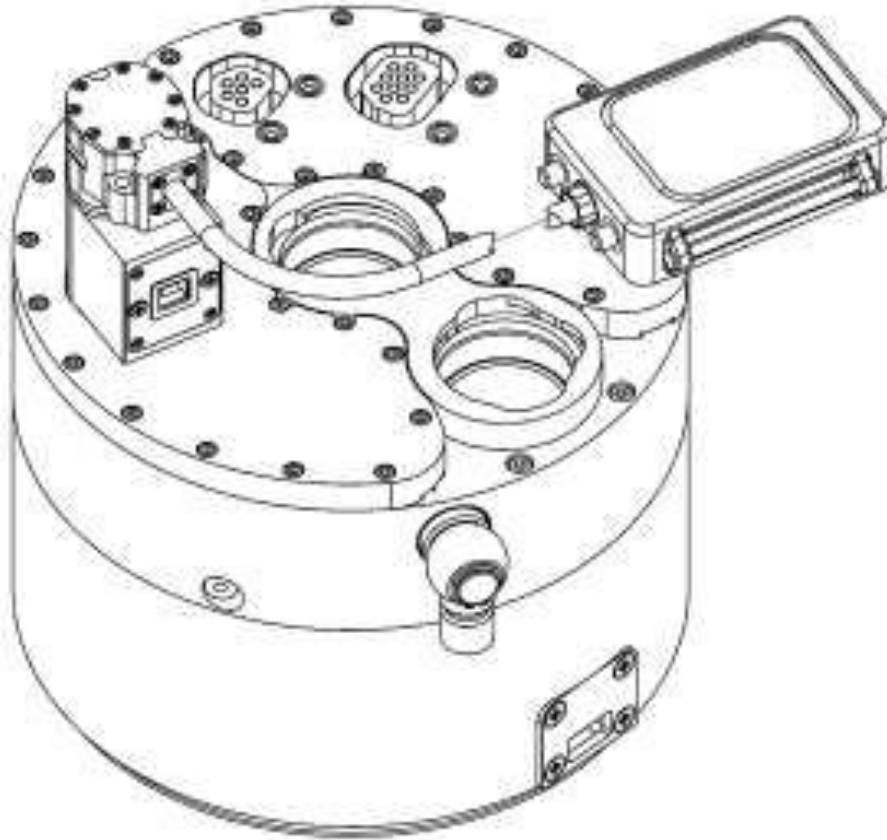

The CCR Liberty's electronics have two different types of firmware (FW): one for the control unit, the other for the handset. It is possible to download the current version from the support page at www.CCRLiberty.com. Perform FW updates in order to maintaining CE certification according to the description on the support page. Perform updates with the head removed from the rebreather's body.

To upgrade your new firmware, use the DIVESOFT.CENTER At the following link you will find the software download, user manual and other important information <https://www.divesoft.com/en/center>.

Minimum operating system requirements for Bluetooth functionality

macOS macOS 11 (Big Sur) Earlier macOS versions USB functions only

Windows Windows 10 or higher Earlier Windows versions USB functions only

Linux Any 64-bit build

3.8 Transport

3.8.1 By car

Transport the CCR Liberty in the case in which it was delivered. Make sure the case is secure and will not move around in the vehicle's cargo space.

The dustiness of the sorbent increases when transported in its loose state in the distribution canister. It is better to transport sorbent in the scrubber cartridge.

3.8.2 By boat

On a dive boat, it is usually possible to fasten the apparatus to a bench.

For securing the rebreather, use a line of approximately 1.5-2 m with secure knots. Tie the apparatus to a suitable structure.

Secure the ready-to-dive CCR Liberty by passing the line over the tanks and backplate, with the scrubber canister pressed to the back of the bench.

If you need to prepare the CCR Liberty for diving while onboard a boat, secure it to a bench using the holes in the upper part of the backplate. This will give you full access to the tanks for filling, and you can easily remove the head and scrubber canister.

3.8.3 By plane

Pressure tanks

Airline regulations generally require that all transported pressure tanks should be empty with the valves dismounted. Place the valves in clean PE bags (Ziploc) and place duct tape over the cylinder necks to prevent contamination. It is possible that security personnel will want to look inside the tanks, do not use tight plugs that are difficult to remove.

When checking in your luggage at the airport, notify the airport personnel that you have empty pressure tanks in your luggage. Depending on local regulations, it is possible that you will have to take the tanks to a special check-in desk.

Consider whether it might be better to rent tanks at your destination. Dive centers equipped for closed-circuit diving usually have available tanks that can be used with the CCR Liberty. If you want to arrange a tank rental, which is highly recommended, refer to the size specifications available at divesoft.com.

When traveling by plane, it is advisable to separate the head of the device and transport it in the hand luggage. You will significantly reduce the weight of your checked luggage, and you will have the most expensive and sensitive part of your device under constant vigil. Be prepared to explain to airport staff that the head is a vital part of modern diving gear and you have this manual with you.

Sorbent

The sorbent canister should be empty. If you are also transporting a supply of sorbent, it must be in the original packaging or in an appropriately sturdy and airtight container. Familiarize yourself with the regulations concerning the air transport of sorbent. Consider the possibility of purchasing sorbent at your destination.

Head

For the purposes of air transport, the batteries must be disconnected by removing or turning the battery jumpers. Do not transport the CCR Liberty in standby mode.

CCR Liberty User Manual

Author

Adam Procháska, Jakub Šimánek, Aleš Procháska.

Publisher

Divesoft s.r.o. divesoft.com

Issue

Revision 2.11 August 2021

Use of this manual approved by

Lucie Šmejkalová, CEO

EC Type-examination for Directive 89/686/EEC by

Notified body No. 0120, SGS United Kingdom Ltd. Unit 202b, Worle Parkway, Weston-super-Mare, BS22 6WA, UK.

PPE Regulation EU 2016/425 Module D by

Notified Body No. 0598 SGS FIMKO P.O.Box 30 (Särkiniementie 3), 00211 Helsinki, Finland From 9th December 2020

UKCA marking Approved body No. 0120, SGS United Kingdom Ltd. Unit 202b, Worle Parkway, Weston-super-Mare, BS22 6WA, UK.

Declaration of conformity available at:

<https://divesoft.com/en/products/ccr-liberty/documents>

Product manufactured by

Divesoft s.r.o. Hálkova 2495 413 01 Roudnice nad Labem Czech Republic



Certificate F118/962366

The management system of

Divesoft, s.r.o.

Hálkova 2495, Roudnice nad Labem, 413 01, Czech Republic

has been assessed and certified as meeting the requirements of

Regulation (EU) 2016/425

Module D

For the following activities

Manufacture of self-contained re-breathing diving apparatus.

Note: All products marked CE0598 must have a valid EU type-examination certificate issued under Module B or a valid EC type-examination certificate issued under Article 10 of the PPE Directive 89/686/EEC.

This certificate is valid from 09 December 2020 until 09 December 2023 and remains valid subject to satisfactory surveillance audits.

Re certification audit due before 19 November 2023

Issue 3, Certified since 22 November 2018

Authorised by

SGS FIMKO OY, Notified Body 0598

Takomitie 8, FI-00380 Helsinki, Finland

t +358 9 696 361 | f +358 9 692 5474 | www.sgs.com

Page 1 of 1



This document is a Web version of SGS certificate for electronic use exclusively. It shall only be available by clicking on SGS Certification Mark which has been posted on Your website. It shall not be printed in anyway. This document is copyright protected. No content or appearance may be reproduced without the express written permission of SGS. Any misuse, alteration, forgery or falsification is unlawful.

Liberty systems, s.r.o.

EC Directive 89/686/EEC

EC Type-examination

Issue 1

PPE Product

CCR Liberty - a closed circuit electronically controlled rebreather with a maximum operating depth 100 m. The device incorporates over the shoulder mounted counterlungs, a radial scrubber, two controller/handsets, head up display, automatic diluent valve with an inline isolation valve, manual O2 addition, manual diluent addition and an intergrated wing style buoyancy control device. The device is required to be used with an autonomous bailout system in accordance with the manufacturers user information notice

It is certified that the manufacturer's technical file and the above mentioned PPE have been assessed and found to be in accordance with the requirements of Council Directive 89/686/EEC. When examined the PPE satisfied the relevant requirements in the harmonized standard,

EN 14143:2013

The manufacturer's information notice (CCR Liberty Dated 27 November 2014), in English, has been inspected and found to have addressed all of the relevant requirements of the standard. However, the detailed content of the information notice is the responsibility of the manufacturer, as are translations into other languages.

This certificate is issued on the strict condition that appropriate checks on manufactured PPE, as detailed in Article 11 of the directive, are implemented and maintained while the model is in production.

Certification is based on technical file reference: CCR Liberty Technical file dated 8th September 2014, & supplemental Documents..

SGS Reference Number GB/PP 233262

This certificate remains the property of SGS United Kingdom Ltd to whom it must be returned on request.

Liberty systems, s.r.o.

K Haltýř 756/14,
Praha 8,
180 00,
Czech Republic.

It is certified that the manufacturer's technical file and the PPE product detailed on page 2 have been assessed and found to be in accordance with

EC Directive 89/686/EEC

EC Type-examination

This certificate is valid from 28 November 2014
Issue 1. Certified since 28 November 2014

Authorised by

SGS United Kingdom Limited, Notified Body 0120
Unit 202B Worle Parkway, Weston-super-Mare, BS22 6WA, United Kingdom
t +44 (0)1934 522917f +44 (0)1934 522137
e-mail sgsprodcert@sgs.com www.sgs.com

SGS EC 03 1011

This certificate remains the property of SGS United Kingdom Ltd to whom it must be returned on request.
Page 1 of 2

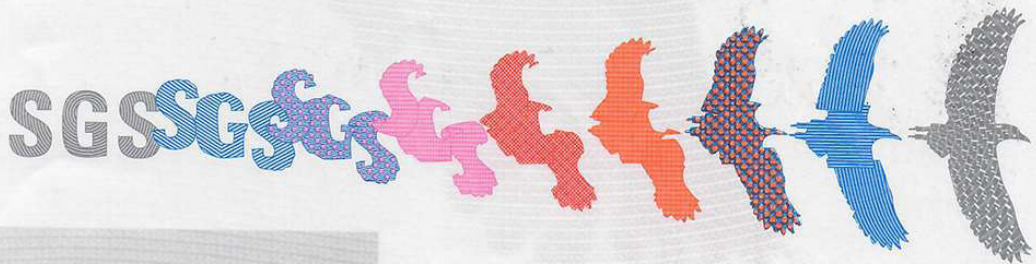

Certificate GB18/962366

The management system of

Divesoft, s.r.o.

Hábkova 2495, Roudnice nad Labem, 413 01, Czech Republic

has been assessed and certified as meeting the requirements of

REG (EU) 2016/425 D

For the following activities

Manufacture of self-contained re-breathing diving apparatus.

Note: All products marked UKCA 0120 must have a valid UKCA type-examination certificate issued under Module B or a valid Article 10 of the PPE Directive 89/686/EEC.

This certificate is valid from 14 January 2022 until 09 December 2023 and remains valid subject to satisfactory surveillance audits.

Issue 4, Certified since 22 November 2018.

Authorised by



SGS United Kingdom Ltd.

Rossmore Business Park, Ellesmere Port, Cheshire, CH65 3EN, UK

1+44 (0)151 350-6666 - www.sgs.com



This document is issued by the Company subject to its General Conditions of Certification Services accessible at www.sgs.com/terms_and_conditions.html. Attention is drawn to the limitations of liability, indemnification and jurisdictional issues established therein. The authenticity of this document may be verified at <http://www.sgs.com/en/certified-clients-and-products/certified-client-directory>. Any unauthorized alteration, forgery or falsification of the content or appearance of this document is unlawful and offenders may be prosecuted to the fullest extent of the law.



SGS