



XT3514K

TELEHANDLERS

Comply with ANSI/CSA



XT3514K

TELEHANDLERS

Specifications

ITEM	XT3514K
------	---------

Measurements

Overall length (without fork)	6074mm
Overall width	2350mm
Overall height	2450mm
Fork length	1200mm
Fork width	122mm
Fork height	50mm
Boom length	/
Wheelbase	3490mm
Ground clearance	400mm
Turning radius(inside/outside)	3922mm/4100mm

Productivity

Max. lift capacity	3500kg
Max. lifting height	13.4m
Max. outreach	9.3m
Max. travel speed	32km/h
Max. height lifting capacity	2000kg
Max. amplitude lifting capacity	500kg
Unladen lifting/lowering speed	13s/9s
Unladen Extension/retraction speed	17s/14s
Gradeability(overload)	35%

Technical Data

Tilting angle of fork(tip up/tip down)	-14°/112°
Hydraulic system pressure	280bar
Hydraulic oil tank volume	135L
Fuel tank volume	130L
Hollow tire	400/80-R24

Power source

Make/model	Deutz/BF4M2012
Rated power	72kW/2200 rpm
Max torque	375N·m/1600 rpm

Transmission

Make/model	/
No. of gear	/

Weight

Total vehicle cube weight(with forks)	10500kg
---------------------------------------	---------

The available attachments include but not limited to the following

Hook	
Forks	
Winch	
Bucket	
Basket	
Log clamp	
Workplatform	
Cylinder clamp	

Range of motion GTH-XT3514K with stabilizers up

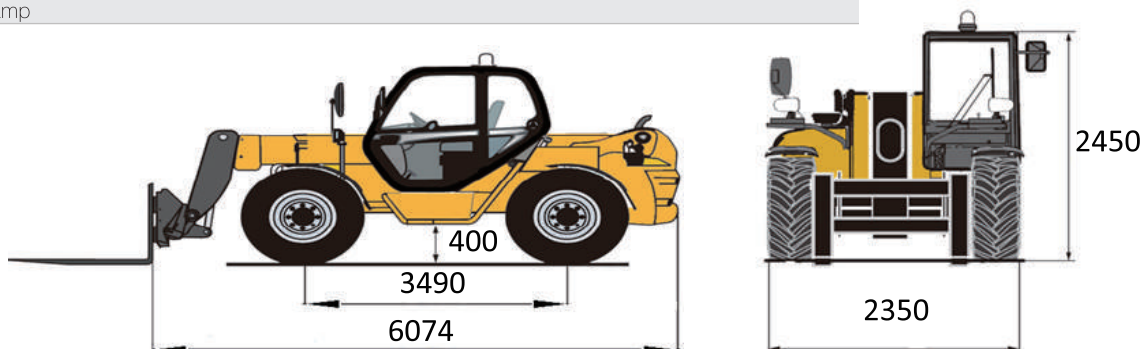
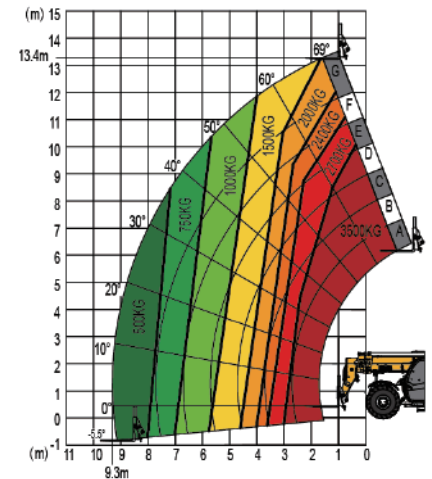

SOLID TO SUCCEED